

DELIVERING GLOBAL SOURCING AND DESIGN SOLUTIONS

www.AmericanChrome.com

800-562-4488

Quality Matters

American Chrome Company is proud to provide premium quality OEM grade heavy truck accessories for over 25+ years. Founded in 1983, American Chrome® is a recognized leader in supplying the heavy truck and RV industries. Quality is not just a word we use, it is the defining difference in how American Chrome® manufactures our products and why our customers have made us one of the most successful chrome, stainless steel, and PC / ABS plastic suppliers in North America. Our wheel products and other fine exterior accessories come in three basic types:

The logo for ABS Chrome features the letters 'ABS' in a large, bold, metallic font with a 3D effect. Below 'ABS', the word 'Chrome' is written in a smaller, similar metallic font.

ABS chrome is our most popular product line due to long life and performance. ABS chrome products are manufactured from high temperature, high impact automotive ABS resins, and are ideal for applications involving extreme environments, where road damage and rust is a frequent problem.

When nothing less than a brilliant, high gloss shine will do, American Chrome's SuperPremium chrome products are the choice for you. SuperPremium chrome products feature a long-lasting, high-gloss shine, a durable mirror finish, and excellent rust and corrosion resistance. Using a proprietary process, SuperPremium chrome products have multiple layers of chrome and nickel plating. All chrome is NOT created equal. The customers who purchase our products know the difference.

The logo for Super Premium features the word 'SUPER' in a large, bold, metallic font with a 3D effect. Below 'SUPER', the word 'premium' is written in a smaller, similar metallic font.The logo for Stainless Steel features the word 'STAINLESS' in a large, bold, metallic font with a 3D effect. Below 'STAINLESS', the word 'steel' is written in a smaller, similar metallic font.

Stainless steel is available in many different quality grades, and while they are all referred to collectively as "stainless steel", only the highest grades of stainless steel exhibit true rust-proof behavior. Additionally, only the highest quality steels have a brilliant 'mirror finish', which is an indication of the quality of the surface polish and ability to reflect light. American Chrome® recommends only the highest grade stainless steel products.

Verisys
Registrars®
ISO 9001:2008
Certified

Verisys
Registrars®
ISO 14001:2004
Certified



CHICAGO
MSDC
MINORITY SUPPLIER
DEVELOPMENT COUNCIL

Certified Minority Business



Certified
WBENC
Women's Business Enterprise



AXLE PRODUCTS

ABS FRONT AXLE COVER KITS	6
ABS REAR AXLE COVER KITS	9
ABS REPLACEMENT PARTS	11
FRONT AXLE COVER KITS	13
REAR AXLE COVER KITS	15
AXLE COVER PARTS	18

EXHAUST PRODUCTS

CHROME STACKS	21
HEAT SHIELDS	24

HUB CAPS

FRONT HUB CAPS	29
REAR HUB CAPS	34
TRAILER HUB CAPS	39

MUD FLAP PRODUCTS

MUD FLAP HANGERS	43
MUD FLAP HANGER PARTS	45
MUD FLAP WEIGHTS	46
ANTI-SAIL BRACKETS	49
LIGHT BARS	50
LIGHT BRACKETS	52
REPLACEMENT LIGHT & GROMMETS	54

NUT COVERS

ABS CHROME NUT COVERS	58
NUT COVERS	63
CHROME BOLT COVERS	68
NUT COVER INSTALLATION TOOLS	69

QUARTER FENDERS

QUARTER FENDERS	72
QUARTER FENDER PARTS	73

SIMULATOR PRODUCTS

LIGHT-DUTY SIMULATOR SETS	76
WHEEL SIMULATOR KITS	77
FRONT WHEEL SIMULATORS	80
REAR WHEEL SIMULATORS	81

WHEEL COVERS

FRONT WHEEL COVER KITS	84
FRONT WHEEL COVERS	86

MIRRORS

MIRRORS	89
---------	----

OTHER PRODUCTS

AIR HORNS	93
AIR HORN COVERS	96
BUMPER GUIDES	97
BUMPER GUIDE PARTS	99
BOOT BRUSH, POGO STICK & PIN PULLER	100
DECORATIVE HARDWARE & PLACARDS	101
ELECTRIC DASH FANS	102
GREASE GUNS	103
HYDRAULIC BOTTLE JACKS	104
LICENSE FRAMES	105
REAR LICENSE PANELS	106
LICENSE PLATE HOLDERS	107
PERMIT HOLDERS	108
LIGHTS	109
LIGHT PARTS	111
RETAIL DISPLAYS	112
RV AXLE END COVERS	113
UNIVERSAL JOINTS	114

APPENDIX

CAD DRAWINGS	115
PART NUMBER INDEX	123
KEYBOARD INDEX	129
GENERAL POLICIES	132
SHIPPING & FREIGHT POLICIES	133
WARRANTY & RETURN POLICIES	134
CERTIFICATIONS	135
ABOUT AMERICAN CHROME®	136
Millimeters to Inches conversion table	137

AXLE PRODUCTS

Quality ABS
Chrome and
Stainless Steel
Axle Cover
Kits, featuring
our exclusive
chrome plating
finish and grade
304 stainless
steel. Ask
about our new
designs.



Product Information - ABS Front & Rear Axle Covers

All Kits Include:

- 10 ABS Chrome Nut Covers (see Styles)
- One-Piece/Two-piece ABS Axle Cover/Cap Assembly
- Plastic Rim Protector
- Steel Locking Washer (for 'Push-On' style only)



Twist-on (Threaded) Nut Covers - Threaded nut covers are the preferred method for securing the ABS Hub Cover to the wheel. Interior threads on the Nut Cover attach securely to the wheel studs, holding the entire assembly onto the wheel.

Push-On Nut Covers - These nut covers are designed for applications when insufficient thread exists on the wheel studs for a secure fit.

Retaining Washer - Used with Push-On style Nut Covers to secure the Hub Cover to the wheel. 2 are included with ABS kits specified with Push-On nut covers.

Removable Cap - Allows access to the assembly without the need to remove the wheel cover. All models of our Rear ABS Axle Covers feature a removable cap.

Non-Removable Caps - For applications where access to the axle is not required, or when the wheels will be exposed to extreme conditions such as commonly found on construction sites and other off-road situations.

Plastic Rim Protector - These clear plastic Rim Protectors are included with all ABS Wheel Cover kits to protect the rims of aluminum wheels from abrasive damage and wear marks.



33mm Threaded Nut Covers - Installed by threading onto the exposed stud above the wheel lug nut.

33mm Push-On Nut Covers - Secured onto the wheel by friction fitting over the wheel lug nut. Use when studs are too short to provide a positive grip.

1.5" Push-On Nut Covers - Secured onto the wheel by friction fitting over the wheel lug nut.

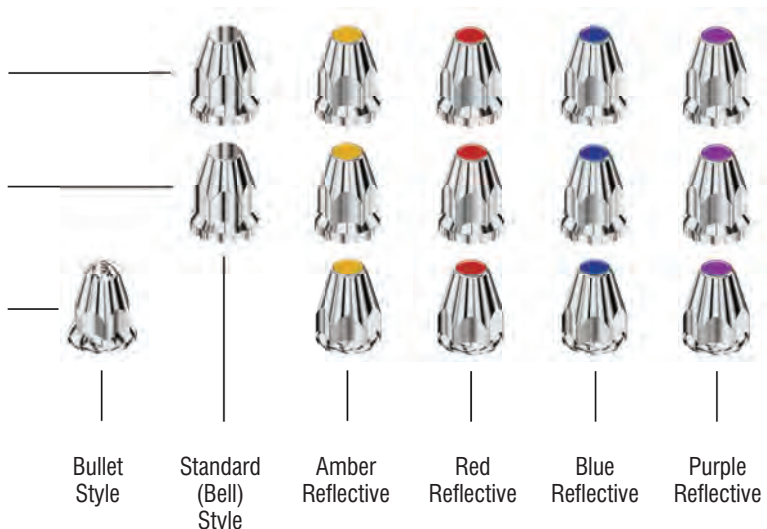

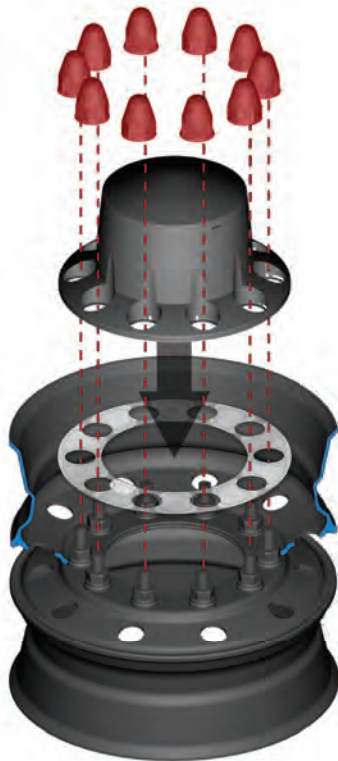

Twist-On

Installation- Place the Rim Protector, followed by the ABS Hub Cover over the existing lug nuts. Holding the ABS Hub Cover flush with the face of the wheel, twist the ABS nut covers onto the exposed studs until tight. A light clicking sound will indicate that the locking action is working, which will secure the lug nut covers in place.

Lug Nut removal is not required!

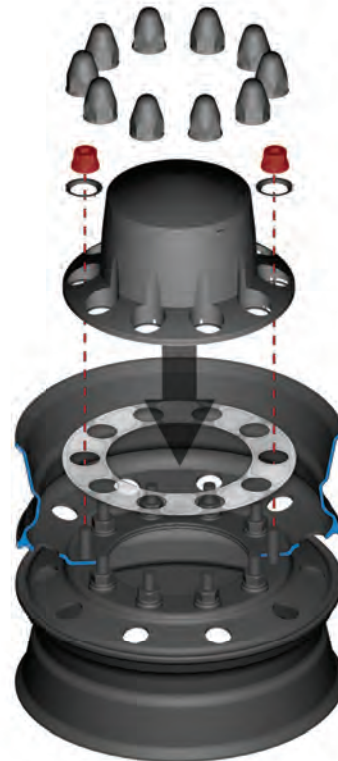

Push-On

Installation- Remove two lug nuts from the wheel, on opposite sides. Place the Rim Protector, followed by the ABS Axle Cover over the existing lug nuts. Replace the two lug nuts removed earlier, using the supplied locking washers to secure the Axle Cover to the wheel. Torque the nuts as usual to complete installation.

Product Information - Rear Axle Covers

Class 7 and 8 truck wheels attach to the axle and hub in one of two ways; **Hub-Piloted** and **Stud Piloted**, as the drawing below shows. Aluminum wheels are typically hub-piloted, and steel wheels are typically stud-piloted. When determining which product to select for your application, it is important to correctly identify the type of wheel and the method of installation for your wheels for a secure and accurate fit.

Products that attach using the lug nuts to secure the product to the wheel, such as beauty rings, hub covers, and wheel simulators specify which application they are intended for. This does not apply however, to our line of ABS axle covers, which are universal and can mount to any style wheel.

Installation Notes



To maximize the life and look of your new American Chrome® Wheel and Hub Covers, it is important not to over-torque the lug nuts during installation. Over-torquing can result in premature failure of the product, or the development of cracks around the lug holes due to compression and metal fatigue.

1.5" Lug Nuts - Most Stud-Piloted wheels use a 1.5" lug nut, with a conical face that helps center the wheel as it is tightened. Products designed to attach using these lug nuts feature a tapered opening to accommodate the conical face of the lug nut, as shown below.

Stud-Piloted

Removable Caps - Many of our Rear Wheel products feature a removable cap, allowing easy access to the hub for maintenance.

Lug Holes - There are usually ten (10) lug holes located around the perimeter of the Beauty Ring. For Stud-Piloted applications, there are five 1.25" tapered holes, and five 1.75" flat holes that slip over existing lug nuts.

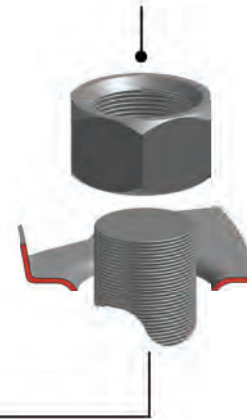
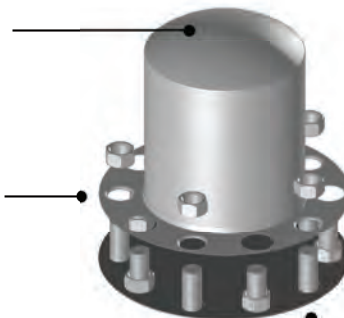

Hub-Piloted

33mm Lug Nuts - Most Hub-Piloted wheels use a 33mm lug nut, with a flat face. The lug nuts usually incorporate an integral washer at the base.

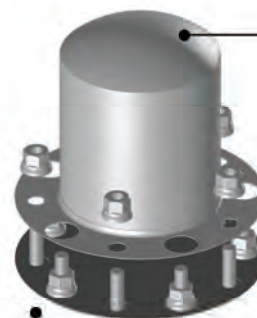

Removable Caps - Many of our Rear Wheel products feature a removable cap, allowing easy access to the hub for maintenance.

Lug Holes - There are usually ten (10) lug holes located around the perimeter of the Beauty Ring. For Hub-Piloted applications, there are five 1" flat holes, and five 1.88" flat holes that slip over the existing lug nuts. As with all our wheel products, it is only necessary to remove five of the lug nuts for proper installation.

ABS FRONT AXLE COVER KITS



ABS Front Axle Cover Kit with Removable Cap

	Lug Holes	Nut Cover Size	Nut Cover Flange	Reflector	Application
15010	10	1.5"	Yes	Amber	Push-On
15020	10	1.5"	Yes	Red	Push-On
15030	10	1.5"	Yes	Blue	Push-On
15040	10	1.5"	Yes	Purple	Push-On
15100	10	33mm	Yes	-	Threaded
15110	10	33mm	Yes	Amber	Threaded
15120	10	33mm	Yes	Red	Threaded
15130	10	33mm	Yes	Blue	Threaded
15140	10	33mm	Yes	Purple	Threaded
15200*	10	33mm	Yes	-	Push-On
15210*	10	33mm	Yes	Amber	Push-On
15220*	10	33mm	Yes	Red	Push-On
15230*	10	33mm	Yes	Blue	Push-On
15240*	10	33mm	Yes	Purple	Push-On

* Parts 15200 - 15240 for use with Short Studs.



ABS Front Axle Cover Kit with Bullet-Style Nut Covers

	Lug Holes	Nut Cover Size	Nut Cover Flange	Reflector	Application
15000	10	1.5"	Yes	-	Push-On

ABS Black Chrome Front Axle Cover Kit

	Lug Holes	Nut Cover Size	Nut Cover Flange	Reflector	Application
15105	10	33mm	Yes	-	Threaded

Five-Spoke Front Axle Cover Kit*

	Lug Holes	Nut Cover Size	Nut Cover Flange	Reflector	Application
15300	10	33mm	Yes	-	Threaded

* To install the Hex Style ABS Chrome Nut Covers (18700) in 5-Spoke Axle Cover Kits (15300 and 15800), use Installation Adapter (15991) with Nut Cover Installation Tube (15990).



ABS Front Axle Cover Kit with Non-Removable Cap

	Lug Holes	Nut Cover Size	Nut Cover Flange	Reflector	Application
40000	10	33mm	Yes	-	Threaded
40010	10	33mm	Yes	Amber	Threaded
40020	10	33mm	Yes	Blue	Threaded
40030	10	33mm	Yes	Purple	Threaded
40040	10	33mm	Yes	Red	Threaded
40050	10	1.5"	Yes	-	Push-On
40060	10	1.5"	Yes	Amber	Push-On
40070	10	1.5"	Yes	Blue	Push-On
40080	10	1.5"	Yes	Purple	Push-On
40090	10	1.5"	Yes	Red	Push-On

ABS REAR AXLE COVER KITS



ABS Rear Axle Cover Kit with Removable Cap

	Lug Holes	Nut Cover Size	Nut Cover Flange	Reflector	Application
15510	10	1.5"	Yes	Amber	Push-On
15520	10	1.5"	Yes	Red	Push-On
15530	10	1.5"	Yes	Blue	Push-On
15540	10	1.5"	Yes	Purple	Push-On
15600	10	33mm	Yes	-	Threaded
15610	10	33mm	Yes	Amber	Threaded
15620	10	33mm	Yes	Red	Threaded
15630	10	33mm	Yes	Blue	Threaded
15640	10	33mm	Yes	Purple	Threaded
15700*	10	33mm	Yes	-	Push-On
15710*	10	33mm	Yes	Amber	Push-On
15720*	10	33mm	Yes	Red	Push-On
15730*	10	33mm	Yes	Blue	Push-On
15740*	10	33mm	Yes	Purple	Push-On

* Parts 15700 – 15740 for use with Short Studs.



ABS Rear Axle Cover Kit with Bullet-Style Nut Covers

	Lug Holes	Nut Size	Flange	Reflector	Application
15500	10	1.5"	Yes	-	Push-On

ABS Black Chrome Rear Axle Cover Kit

	Lug Holes	Nut Size	Flange	Reflector	Application
15605	10	33mm	Yes	-	Threaded

Five-Spoke Rear Axle Cover Kit*

	Lug Holes	Nut Size	Flange	Reflector	Application
15800	10	33mm	Yes	-	Threaded

* To install the Hex Style ABS Chrome Nut Covers (18700) in 5-Spoke Axle Cover Kits (15300 and 15800), use Installation Adapter (15991) with Nut Cover Installation Tube (15990).

ABS REPLACEMENT PARTS



ABS Axle Cover Center Caps

	Fits Kit Type	Style	Description
15920	Front	Baby Moon	For 15000, 15100, 15200 Series Front Axle Cover Kits
15921	Front	Baby Moon	For 15105 Black Chrome Front Axle Cover Kit
15925	Front	Baby Moon	For 15300 5-Spoke Style Front Axle Cover Kit
15930	Front	Hubdometer	For 15000, 15100, 15200, 15300 Series Front Axle Cover Kits
15960	Rear	Baby Moon	For Series 15500, 15600, 15700 Rear Axle Cover Kits
15961	Rear	Baby Moon	For 15605 Black Chrome Rear Axle Cover Kit
15965	Rear	Baby Moon	For 15800 5-Spoke Style Rear Axle Cover Kit
15971	Rear	Hubdometer	For 15500, 15600, 15700, 15800 Series Rear Axle Cover Kits

ABS Nut Cover Installation Bar

Description

- 15990 High-Strength Polymer Lug Nut Cover Bar for Installation and Removal of 33mm and 1.5" ABS Nut Covers.
- 15991 Installation Adapter for Hex Style ABS Chrome Nut Covers part# 18170, used with 15990. Insert 15991 into the end of 15990 to install the Hex Style ABS Chrome Nut Covers (18700) in 5-Spoke Axle Cover Kits (15300 and 15800).



ABS Replacement Nut Covers*

Size and Type	Bullet Style	Standard (Bell) Style	Amber Reflector	Red Reflector	Blue Reflector	Purple Reflector
1.5" Push-On	18002	-	18022	18032	18042	18052
33mm Threaded	-	18102	18122	18132	18142	18152
33mm Push-On	-	18202	18222	18232	18242	18252
33mm Threaded for Black Chrome Kit	-	18110	-	-	-	-
33mm Threaded for 5-Spoke Style Kit	-	18170	-	-	-	-

Rim Protector

Description

15985 Plastic Rim Protector for ABS Axle Cover Kits

Metal Retaining Washer

Description

15980 Metal Retaining Washer for 33mm ABS Front and Rear Axle Cover Kits. Package of 2.

15981 Metal Retaining Washer for 1.5" ABS Front and Rear Axle Cover Kits. Package of 2.

*Replacement Nut Covers Available in 10-piece Blister Package.

FRONT AXLE COVER KITS



Front Axle Cover Kit with Removable Baby Moon Cap*

	Height	Lug Holes	Cap Style	Application	Material
81021	3.5"	(5) 1.25", (5) 1.75"	Baby Moon	Stud-Piloted	CH
81031	3.5"	(5) 1.25", (5) 1.75"	Baby Moon	Stud-Piloted	SS
81023	3.5"	(5) 1", (5) 1.88"	Baby Moon	Hub-Piloted	CH
81033	3.5"	(5) 1", (5) 1.88"	Baby Moon	Hub-Piloted	SS

Front Axle Cover Kit with Non-Removable Baby Moon Cap*

	Height	Lug Holes	Cap Style	Application	Material
81001	3.5"	(5) 1.25", (5) 1.75"	Baby Moon	Stud-Piloted	CH
81011	3.5"	(5) 1.25", (5) 1.75"	Baby Moon	Stud-Piloted	SS
81003	3.5"	(5) 1", (5) 1.88"	Baby Moon	Hub-Piloted	CH
81013	3.5"	(5) 1", (5) 1.88"	Baby Moon	Hub-Piloted	SS

*Use 16961 for Removable Conical Style Axle Cover Kits (front & rear).

*CAD drawings are available from Page 118.



Tall Size Front Axle Cover Kit with Removable Cap *

	Height	Lug Holes	Cap Style	Application	Material
81051	5.9"	(5) 1.25", (5) 1.75"	Baby Moon	Stud-Piloted	SS
81053	5.9"	(5) 1", (5) 1.88"	Baby Moon	Hub-Piloted	SS

Hubdometer Front Axle Cover Kit with Removable Cap *

	Height	Lug Holes	Cap Style	Application	Material
81041	3.5"	(5) 1.25", (5) 1.75"	Hubdometer	Stud-Piloted	CH
81043	3.5"	(5) 1", (5) 1.88"	Hubdometer	Hub-Piloted	CH

*Use 16961 for Removable Conical Style Axle Cover Kits (front & rear).

*CAD drawings are available from Page 119.

REAR AXLE COVER KITS



Rear Axle Cover Kit with Removable Baby Moon Cap *

	Height	Lug Holes	Cap Style	Application	Material
83111	9"	(5) 1.25", (5) 1.75"	Baby Moon	Stud-Piloted	SS
83151	10.5"	(5) 1.25", (5) 1.75"	Baby Moon	Stud-Piloted	CH
83161	10.5"	(5) 1.25", (5) 1.75"	Baby Moon	Stud-Piloted	SS
83113	9"	(5) 1", (5) 1.88"	Baby Moon	Hub-Piloted	SS
83153	10.5"	(5) 1", (5) 1.88"	Baby Moon	Hub-Piloted	CH
83163	10.5"	(5) 1", (5) 1.88"	Baby Moon	Hub-Piloted	SS

Rear Axle Cover Kit with Non-Removable Baby Moon Cap

	Height	Lug Holes	Cap Style	Application	Material
83121	9"	(5) 1.25", (5) 1.75"	Baby Moon	Stud-Piloted	SS
83131	9.5"	(5) 1.25", (5) 1.75"	Baby Moon	Stud-Piloted	CH
83141	9.5"	(5) 1.25", (5) 1.75"	Baby Moon	Stud-Piloted	SS
83123	9"	(5) 1", (5) 1.88"	Baby Moon	Hub-Piloted	SS
83133	9.5"	(5) 1", (5) 1.88"	Baby Moon	Hub-Piloted	CH
83143	9.5"	(5) 1", (5) 1.88"	Baby Moon	Hub-Piloted	SS

*Use 16961 for Removable Conical Style Axle Cover Kits (front & rear).

*CAD drawings are available from Pages 119 - 120.



Hubdometer Rear Axle Cover Kit with Removable Cap*

	Height	Lug Holes	Cap Style	Application	Material
83171	10"	(5) 1.25", (5) 1.75"	Hubdometer	Stud-Piloted	CH
83181	10"	(5) 1.25", (5) 1.75"	Hubdometer	Stud-Piloted	SS
83173	10"	(5) 1", (5) 1.88"	Hubdometer	Hub-Piloted	CH
83183	10"	(5) 1", (5) 1.88"	Hubdometer	Hub-Piloted	SS

Rear Axle Cover**

	Height	Lug Holes	Cap Style	Material
83000	9.5"	-	Baby Moon, Non-Removable	CH
83010	9.5"	-	Baby Moon, Non-Removable	SS
83020	10.5"	-	Baby Moon, Removable	CH
83030	10.5"	-	Baby Moon, Removable	SS

*CAD drawings are available from Page 120.

**Rear Axle Covers don't include beauty rings.

STUD-PILOTED WHEELS

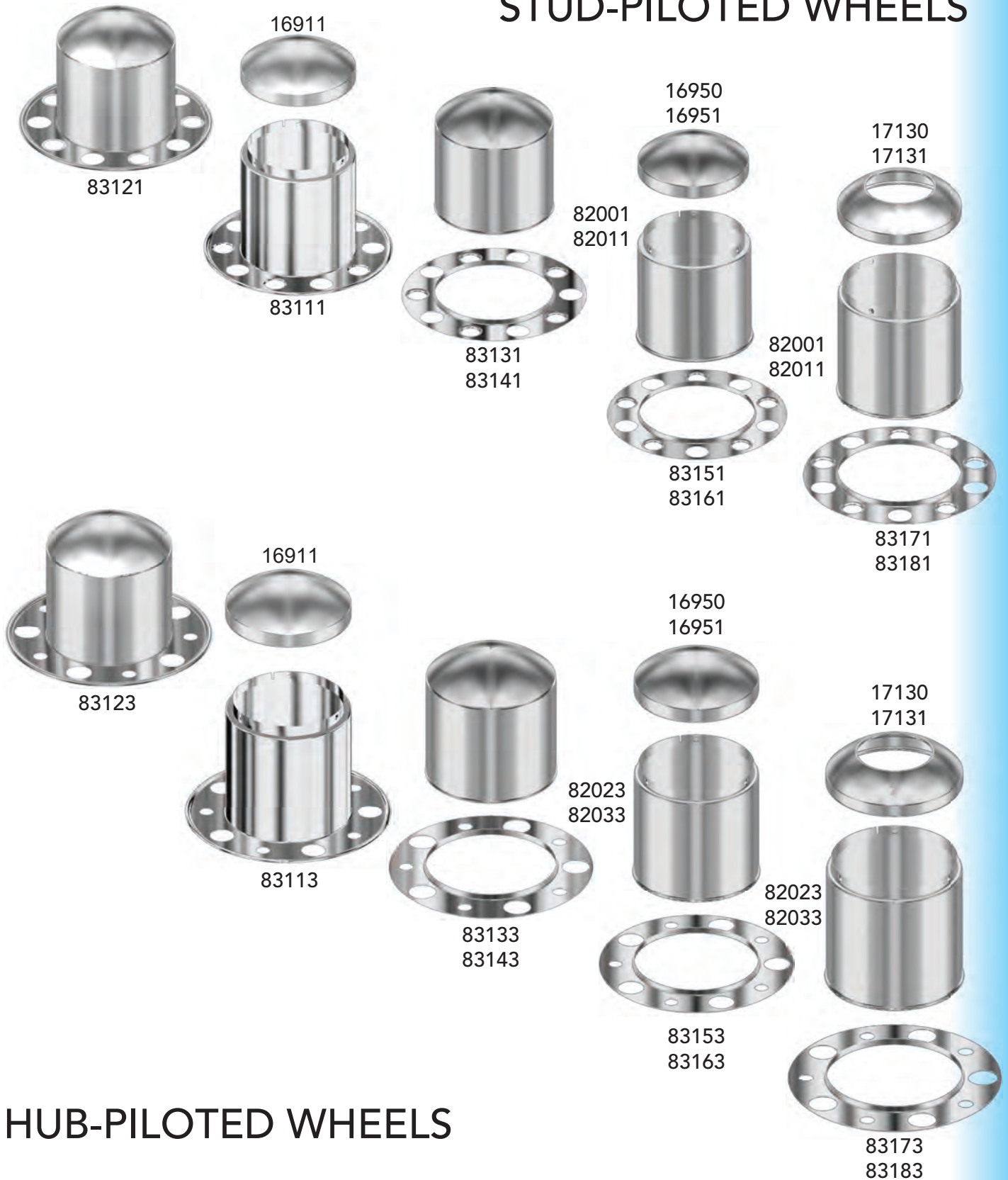

HUB-PILOTED WHEELS

AXLE COVER PARTS



Axle Cover Replacement Parts *

Description

13900	Steel Washer for Beauty Ring (5 pcs pack)
13910	Plastic Rim Protector (for Stainless Axle Covers)
16910	Replacement 'Baby Moon' Style Cap for Rear Axle Cover 83020, 83151, 83153. Chrome
16911	Replacement 'Baby Moon' Style Cap for Rear Axle Cover 83030, 83111, 83113, 83161, 83163. Stainless Steel
16921	Replacement 'Conical' Style Cap for Rear Axle Cover 83020, 83151, 83153. Stainless Steel
16950	Replacement 'Baby Moon' Style Cap for Front Axle Cover 81021, 81023. Chrome
16951	Replacement 'Baby Moon' Style Cap for Front Axle Cover 81031, 81033. Stainless Steel
17130	Replacement 'Hubdometer' Style Cap for Rear Axle Cover 83171, 83173. Chrome
17131	Replacement 'Hubdometer' Style Cap for Rear Axle Cover 83081, 83083. Stainless Steel

Beauty Rings *

	Bolt Circle	Lug Holes	Application	Material
82003	10.83"(275mm)	(8) 1.25"	Hub-Piloted	CH
82013	10.83"(275mm)	(8) 1.25"	Hub-Piloted	SS
82001	11.25"(285mm)	(5) 1.25", (5) 1.75"	Stud-Piloted	CH
82011	11.25"(285mm)	(5) 1.25", (5) 1.75"	Stud-Piloted	SS
82023	11.25"(285mm)	(5) 1", (5) 1.88"	Hub-Piloted	CH
82033	11.25"(285mm)	(5) 1", (5) 1.88"	Hub-Piloted	SS

*CAD drawings are available from Pages 116 - 120.



EXHAUST PRODUCTS

SuperPremium
chrome plating
process on
all American
Chrome Exhaust
Products. All
of our chrome
exceeds a 96 -
hour salt spray
test. OEM
grade quality.

What Makes a Great Chrome Stack?

SuperPremium Chrome - The cost of a Chrome Stack is primarily influenced by the quality and thickness of the Chrome Plate and the amount of chrome and nickel applied. The quality of the plating determines how well the Chrome Stack will survive the elements.

Hot exhaust gasses, rain, salt, and dirt conspire to destroy the finish on your new Chrome Stack, resulting in rapid development of rust and discoloration. Only SuperPremium Chrome stacks feature our exclusive plating process that extends the life of the stack and maintains the beauty and shine for years longer than our competitors.

Miter Cut



Turn Out



Bull Horn



6" Stack



5" Stack



End Type - Expanded

Expanded End - Expanded Chrome Stacks have been mechanically expanded so that the Inside Diameter (ID) of the stack will fit over an existing Exhaust Pipe or Chrome Elbow of the same diameter.

End Type - Plain

Plain End - Chrome Stacks with Plain Ends are unmodified, and are the same diameter along the full length of the Stack. Typically these are used when the customer has an existing Chrome Stack or Elbow that has an Expanded End, allowing the Stack to slip inside.



CHROME STACKS



5" SuperPremium Chrome Stacks

	Length	Diameter	End Diameter	Style	End Type
60501G	18"	5"	5" OD	Turnout	Plain
60503G	18"	5"	5" ID	Turnout	Expanded
60591G	24"	5"	5" OD	Turnout	Plain
60593G	24"	5"	5" ID	Turnout	Expanded
60511G	36"	5"	5" OD	Turnout	Plain
60513G	36"	5"	5" ID	Turnout	Expanded
60521G	48"	5"	5" OD	Turnout	Plain
60523G	48"	5"	5" ID	Turnout	Expanded
60531G	60"	5"	5" OD	Turnout	Plain
60533G	60"	5"	5" ID	Turnout	Expanded
60501	18"	5"	5" OD	Bull Horn	Plain
60503	18"	5"	5" ID	Bull Horn	Expanded
60591	24"	5"	5" OD	Bull Horn	Plain
60593	24"	5"	5" ID	Bull Horn	Expanded
60511	36"	5"	5" OD	Bull Horn	Plain
60513	36"	5"	5" ID	Bull Horn	Expanded
60521	48"	5"	5" OD	Bull Horn	Plain
60523	48"	5"	5" ID	Bull Horn	Expanded
60531	60"	5"	5" OD	Bull Horn	Plain
60533	60"	5"	5" ID	Bull Horn	Expanded



5" SuperPremium Chrome Stacks

	Length	Diameter	End Diameter	Style	End Type
60500	18"	5"	5" OD	Miter Cut	Plain
60502	18"	5"	5" ID	Miter Cut	Expanded
60590	24"	5"	5" OD	Miter Cut	Plain
60592	24"	5"	5" ID	Miter Cut	Expanded
60510	36"	5"	5" OD	Miter Cut	Plain
60512	36"	5"	5" ID	Miter Cut	Expanded
60520	48"	5"	5" OD	Miter Cut	Plain
60522	48"	5"	5" ID	Miter Cut	Expanded
60530	60"	5"	5" OD	Miter Cut	Plain
60532	60"	5"	5" ID	Miter Cut	Expanded



6" SuperPremium Chrome Stacks

	Length	Diameter	End Diameter	Style	End Type
60611G	36"	6"	5" OD	Turnout	Plain
60613G	36"	6"	5" ID	Turnout	Expanded
60621G	48"	6"	5" OD	Turnout	Plain
60623G	48"	6"	5" ID	Turnout	Expanded
60631G	60"	6"	5" OD	Turnout	Plain
60633G	60"	6"	5" ID	Turnout	Expanded
60611	36"	6"	5" OD	Bull Horn	Plain
60613	36"	6"	5" ID	Bull Horn	Expanded
60621	48"	6"	5" OD	Bull Horn	Plain
60623	48"	6"	5" ID	Bull Horn	Expanded
60631	60"	6"	5" OD	Bull Horn	Plain
60633	60"	6"	5" ID	Bull Horn	Expanded
60610	36"	6"	5" OD	Miter Cut	Plain
60612	36"	6"	5" ID	Miter Cut	Expanded
60620	48"	6"	5" OD	Miter Cut	Plain
60622	48"	6"	5" ID	Miter Cut	Expanded
60630	60"	6"	5" OD	Miter Cut	Plain
60632	60"	6"	5" ID	Miter Cut	Expanded

HEAT SHIELDS

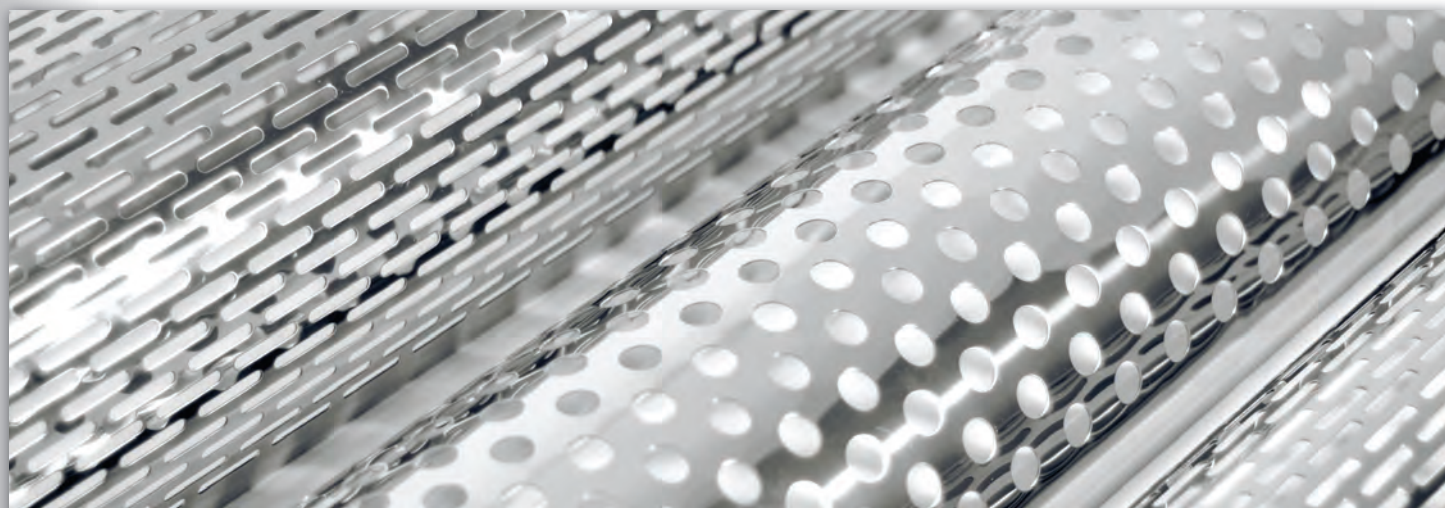

Stainless Steel Heat Shields*

	Length	Fits Muffler Diameter	Coverage	Style	Material
60300	48"	5"	180°	Vertical Holes	SS
60301	48"	5"	180°	Circular Holes	SS
60305	48"	6"	180°	Vertical Holes	SS
60316	48"	6"	180°	Circular Holes	SS
60320	48"	8"	180°	Vertical Holes	SS
60321	48"	8"	180°	Circular Holes	SS
60325	48"	9"	180°	Vertical Holes	SS
60326	48"	9"	180°	Circular Holes	SS
60330	48"	10"	180°	Vertical Holes	SS
60331	48"	10"	180°	Circular Holes	SS
60335	48"	9"	270°	Vertical Holes	SS
60336	48"	9"	270°	Circular Holes	SS

*Clamps sold separately.



Heat Shield Mounts

	Fits Muffler Diameter	Application	Material
60360	5"	180°	Zinc Steel
60366	6"	180°	Zinc Steel
60372	8"	180°	Zinc Steel
60378	9"	180°	Zinc Steel
60384	10"	180°	Zinc Steel
60386	9"	270°	Zinc Steel

Chrome Plated Steel Muffler Clamps

	Diameter	Description
25500	4"	Chrome Plated Steel Muffler Clamp
25501	5"	Chrome Plated Steel Muffler Clamp
25502	6"	Chrome Plated Steel Muffler Clamp

HUB CAPS

OEM grade.
All sizes and
types, front
and rear, in
SuperPremium
chrome and
stainless steel.



Basic Hub Cap Styles



 **Notches** - Most hub caps can be divided into four groups, based on the number and placement of notches around the base. These notches allow the hub cap to fit around the 'locators' on the hub that center the wheel. The four basic notch styles are shown below.



Rear Hub Cap Installation

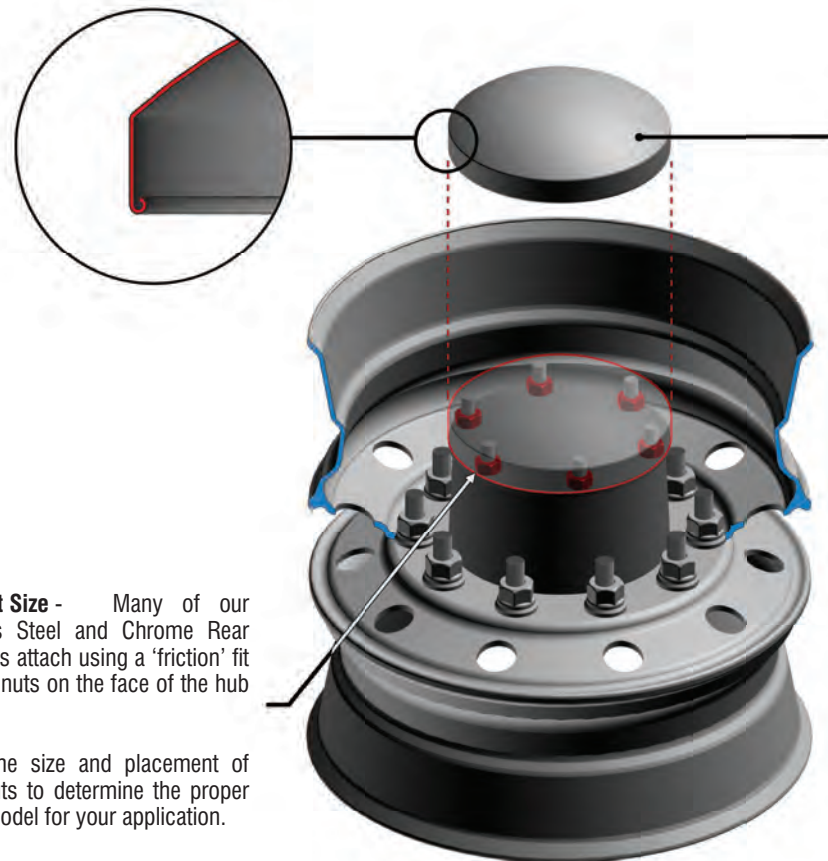

Hub Cap - The inside lip of the hub cap is curled inward, and firm pressure during installation creates a tolerance fit between this edge and the exterior edges of the bolts on the hub plate as shown.

The thickness of this inside lip varies considerably depending on the model and its intended application. If the hub cap fits loosely, the hub cap may be incorrect for the size of nuts on the hub face plate.

Stud/Nut Size - Many of our Stainless Steel and Chrome Rear Hub Caps attach using a 'friction' fit over the nuts on the face of the hub plate.

Check the size and placement of these nuts to determine the proper fit and model for your application.

Trailer Hub Cap Installation

Mounting Bracket - The Mounting Bracket attaches to the hub face using the existing bolts.

Once attached, the Mounting Bracket can be used to secure a standard Rear Wheel Hub Cap such as our part number 16930, 16931.

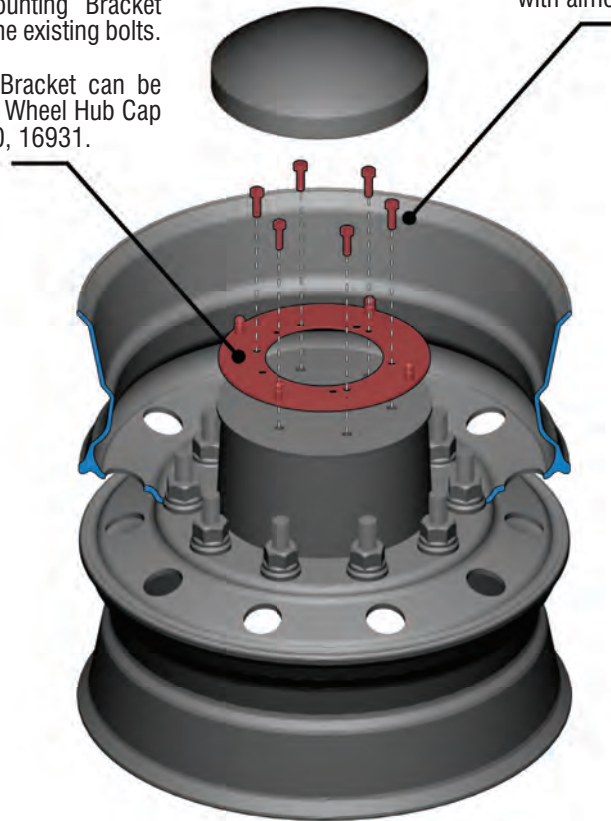

Hub Bolts - Remove several hub plate bolts, and re-attach through the pre-drilled Mounting Bracket holes to secure Bracket to the hub.

The Hub Plate is pre-drilled to accommodate a wide variety of standard trailer axle hubs, and can be easily modified in the field to work with almost any axle style or manufacture.

FRONT HUB CAPS



Baby Moon Front Hub Cap *

	Lip Height	Outside Diameter	Side Wall	Height	Style	Notch	Material	Packaging
16160	1/2"	8 23/32"	1/2"	2 9/16"	Baby Moon	4-Notch	CH	Box of 50
16161	1/2"	8 23/32"	1/2"	2 9/16"	Baby Moon	4-Notch	SS	Box of 50
16162	1/2"	8 23/32"	1/2"	2 9/16"	Baby Moon	4-Notch	CH	BP
16163	1/2"	8 23/32"	1/2"	2 9/16"	Baby Moon	4-Notch	SS	BP
16164	1/2"	8 23/32"	-	2 9/16"	Baby Moon	4-Notch Uneven**	CH	Box of 50
16180	1/2"	8 23/32"	1/2"	2 9/16"	Baby Moon	5-Notch	CH	Box of 50
16181	1/2"	8 23/32"	1/2"	2 9/16"	Baby Moon	5-Notch	SS	Box of 50
16182	1/2"	8 23/32"	1/2"	2 9/16"	Baby Moon	5-Notch	CH	BP
16183	1/2"	8 23/32"	1/2"	2 9/16"	Baby Moon	5-Notch	SS	BP
16250	3/4"	8 23/32"	-	2 9/16"	Baby Moon	6-Notch Uneven	CH	Box of 50
16251	3/4"	8 23/32"	-	2 9/16"	Baby Moon	6-Notch Uneven	SS	Box of 50
16252	3/4"	8 23/32"	-	2 9/16"	Baby Moon	6-Notch Uneven	CH	BP
16253	3/4"	8 23/32"	-	2 9/16"	Baby Moon	6-Notch Uneven	SS	BP
16270	1/2"	8 23/32"	1/2"	2 9/16"	Baby Moon	6-Notch	CH	Box of 50
16271	1/2"	8 23/32"	1/2"	2 9/16"	Baby Moon	6-Notch	SS	Box of 50
16272	1/2"	8 23/32"	1/2"	2 9/16"	Baby Moon	6-Notch	CH	BP
16273	1/2"	8 23/32"	1/2"	2 9/16"	Baby Moon	6-Notch	SS	BP

*CAD drawings are available from Page 115.

**16164 is designed for Gunite Axle 75W90.



Baby Moon Front Hub Cap, Short Lip*

	Lip Height	Outside Diameter	Side Wall	Height	Style	Notch	Material	Packaging
17016	1/2"	8 23/32"	-	2 9/16"	Baby Moon	No Notch, Short Lip	SS	Box of 50
17020	1/2"	8 23/32"	-	2 9/16"	Baby Moon	4-Notch, Short Lip	CH	Box of 50
17021	1/2"	8 23/32"	-	2 9/16"	Baby Moon	4-Notch, Short Lip	SS	Box of 50
17022	1/2"	8 23/32"	-	2 9/16"	Baby Moon	4-Notch, Short Lip	CH	BP
17023	1/2"	8 23/32"	-	2 9/16"	Baby Moon	4-Notch, Short Lip	SS	BP
17025	1/2"	8 23/32"	-	2 9/16"	Baby Moon	5-Notch, Short Lip	CH	Box of 50
17026	1/2"	8 23/32"	-	2 9/16"	Baby Moon	5-Notch, Short Lip	SS	Box of 50
17027	1/2"	8 23/32"	-	2 9/16"	Baby Moon	5-Notch, Short Lip	CH	BP
17028	1/2"	8 23/32"	-	2 9/16"	Baby Moon	5-Notch, Short Lip	SS	BP

Baby Moon Front Hub Cap for Aluminum Wheels*

	Lip Height	Outside Diameter	Side Wall	Height	Style	Notch	Material	Packaging
16100	1"	8 23/32"	-	2 5/8"	Baby Moon	No Notch	CH	Box of 50
16102	1"	8 23/32"	-	2 5/8"	Baby Moon	No Notch	CH	BP
16110	11/16"	8 23/32"	-	2 3/8"	Baby Moon	4-Notch	CH	Box of 50
16112	11/16"	8 23/32"	-	2 3/8"	Baby Moon	4-Notch	CH	BP

*CAD drawings are available from Page 115.



Front Hub Cap for Meritor Unitized Axle*

	Lip Height	Outside Diameter	Side Wall	Height	Style	Notch	Material	Packaging
16120	5/16"	8 23/32"	-	2"	Baby Moon	No Notch	CH	Box of 50
16121	5/16"	8 23/32"	-	2"	Baby Moon	No Notch	SS	Box of 50
16122	5/16"	8 23/32"	-	2"	Baby Moon	No Notch	CH	BP
16123	5/16"	8 23/32"	-	2"	Baby Moon	No Notch	SS	BP

Conical Front Hub Cap*

	Lip Height	Outside Diameter	Side Wall	Height	Style	Notch	Material	Packaging
16150	1/2"	8 23/32"	1/2"	3 5/64"	Conical	4-Notch	CH	Box of 50
16151	1/2"	8 23/32"	1/2"	3 5/64"	Conical	4-Notch	SS	Box of 50
16152	1/2"	8 23/32"	1/2"	3 5/64"	Conical	4-Notch	CH	BP
16153	1/2"	8 23/32"	1/2"	3 5/64"	Conical	4-Notch	SS	BP
16170	1/2"	8 23/32"	1/2"	3 5/64"	Conical	5-Notch	CH	Box of 50
16171	1/2"	8 23/32"	1/2"	3 5/64"	Conical	5-Notch	SS	Box of 50
16172	1/2"	8 23/32"	1/2"	3 5/64"	Conical	5-Notch	CH	BP
16173	1/2"	8 23/32"	1/2"	3 5/64"	Conical	5-Notch	SS	BP

*CAD drawings are available from Pages 115 - 116.



Conical Front Hub Cap *

	Lip Height	Outside Diameter	Side Wall	Height	Style	Notch	Material	Packaging
16240	1/2"	8 23/32"	1/2"	3 5/64"	Conical	6-Notch, Uneven	CH	Box of 50
16241	1/2"	8 23/32"	1/2"	3 5/64"	Conical	6-Notch, Uneven	SS	Box of 50
16242	1/2"	8 23/32"	1/2"	3 5/64"	Conical	6-Notch, Uneven	CH	BP
16243	1/2"	8 23/32"	1/2"	3 5/64"	Conical	6-Notch, Uneven	SS	BP

Hubdometer Front Hub Cap *

	Lip Height	Outside Diameter	Side Wall	Height	Style	Notch	Material	Packaging
16500	1/2"	8 23/32"	1/2"	2 9/16"	Hubdometer	4-Notch	CH	Box of 50
16501	1/2"	8 23/32"	1/2"	2 9/16"	Hubdometer	4-Notch	SS	BP
16502	1/2"	8 23/32"	1/2"	2 9/16"	Hubdometer	4-Notch	CH	Box of 50
16503	1/2"	8 23/32"	1/2"	2 9/16"	Hubdometer	4-Notch	SS	BP
16510	1/2"	8 23/32"	1/2"	2 9/16"	Hubdometer	5-Notch	CH	Box of 50
16511	1/2"	8 23/32"	1/2"	2 9/16"	Hubdometer	5-Notch	SS	BP
16512	1/2"	8 23/32"	1/2"	2 9/16"	Hubdometer	5-Notch	CH	Box of 50
16513	1/2"	8 23/32"	1/2"	2 9/16"	Hubdometer	5-Notch	SS	BP

*CAD drawings are available from Page 116.



Hubdometer Front Hub Cap *

	Lip Height	Outside Diameter	Side Wall	Height	Style	Notches	Material	Packaging
16520	1/2"	8 23/32"	1/2"	2 9/16"	Hubdometer	6-Notch	CH	Box of 50
16521	1/2"	8 23/32"	1/2"	2 9/16"	Hubdometer	6-Notch	SS	Box of 50
16522	1/2"	8 23/32"	1/2"	2 9/16"	Hubdometer	6-Notch	CH	BP
16523	1/2"	8 23/32"	1/2"	2 9/16"	Hubdometer	6-Notch	SS	BP
16530	7/8"	8 23/32"	1/2"	2 9/16"	Hubdometer	6-Notch, Uneven	CH	Box of 50
16531	7/8"	8 23/32"	1/2"	2 9/16"	Hubdometer	6-Notch, Uneven	SS	Box of 50
16532	7/8"	8 23/32"	1/2"	2 9/16"	Hubdometer	6-Notch, Uneven	CH	BP
16533	7/8"	8 23/32"	1/2"	2 9/16"	Hubdometer	6-Notch, Uneven	SS	BP

Front Hub Cap Clips

Description

16650 Front Hub Cap Clips - Package of 4

16660 Front Hub Cap Clips - Package of 5

16670 Front Hub Cap Clips for 'Meritor Disposable Axle' - Package of 4

*CAD drawings are available from Page 116.

REAR HUB CAPS



Rear Hub Cap for 7 1/4" Diameter Axles*

	Height	Side Wall	Inside Diameter	Style	Fit Stud Size	Material	Packaging
16900	2 5/8"	1 3/16"	7 1/4"	Baby Moon	12 of 1/2", 8 of 9/16"	CH	Box of 50
16901	2 5/8"	1 3/16"	7 1/4"	Baby Moon	12 of 1/2", 8 of 9/16"	SS	Box of 50
16902	2 5/8"	1 3/16"	7 1/4"	Baby Moon	12 of 1/2", 8 of 9/16"	CH	BP
16903	2 5/8"	1 3/16"	7 1/4"	Baby Moon	12 of 1/2", 8 of 9/16"	SS	BP
17100	2 1/8"	1 3/16"	7 1/4"	Hubdometer	12 of 1/2", 8 of 9/16"	CH	Box of 50
17101	2 1/8"	1 3/16"	7 1/4"	Hubdometer	12 of 1/2", 8 of 9/16"	SS	Box of 50
17102	2 1/8"	1 3/16"	7 1/4"	Hubdometer	12 of 1/2", 8 of 9/16"	CH	BP
17103	2 1/8"	1 3/16"	7 1/4"	Hubdometer	12 of 1/2", 8 of 9/16"	SS	BP

Rear Hub Cap for 8 1/4" Diameter Axles*

	Height	Side Wall	Inside Diameter	Style	Fit Stud Size	Material	Packaging
16930	2 3/4"	1 1/16"	8"	Baby Moon	8 of 5/8"	CH	Box of 50
16931	2 3/4"	1 1/16"	8"	Baby Moon	8 of 5/8"	SS	Box of 50
16932	2 3/4"	1 1/16"	8"	Baby Moon	8 of 5/8"	CH	BP
16933	2 3/4"	1 1/16"	8"	Baby Moon	8 of 5/8"	SS	BP
16934	3"	1 5/16"	8"	Baby Moon	8 of 5/8"	CH	Box of 50

*CAD drawings are available from Pages 116 - 118.



Rear Hub Cap for 8 1/4" Diameter Axles*

	Height	Side Wall	Inside Diameter	Style	Fit Stud Size	Material	Packaging
16940	3 1/16"	1 1/16"	8"	Conical	8 of 5/8"	CH	Box of 50
16941	3 1/16"	1 1/16"	8"	Conical	8 of 5/8"	SS	Box of 50
16942	3 1/16"	1 1/16"	8"	Conical	8 of 5/8"	CH	BP
16943	3 1/16"	1 1/16"	8"	Conical	8 of 5/8"	SS	BP
17120	2 1/8"	1 1/16"	8"	Hubdometer	8 of 5/8"	CH	Box of 50
17121	2 1/8"	1 1/16"	8"	Hubdometer	8 of 5/8"	SS	Box of 50
17122	2 1/8"	1 1/16"	8"	Hubdometer	8 of 5/8"	CH	BP
17123	2 1/8"	1 1/16"	8"	Hubdometer	8 of 5/8"	SS	BP

Rear Hub Cap for 8 1/2" Diameter Axles*

	Height	Side Wall	Inside Diameter	Style	Fit Stud Size	Material	Packaging
16950	2 7/8"	7/8"	8 3/16"	Baby Moon	8 of 3/4"	CH	Box of 50
16951	2 7/8"	7/8"	8 3/16"	Baby Moon	8 of 3/4"	SS	Box of 50
16952	2 7/8"	7/8"	8 3/16"	Baby Moon	8 of 3/4"	CH	BP
16953	2 7/8"	7/8"	8 3/16"	Baby Moon	8 of 3/4"	SS	BP

*CAD drawings are available from Pages 117 - 118.



Rear Hub Cap for 8 1/2" Axles*

	Height	Side Wall	Inside Diameter	Style	Fit Stud Size	Material	Packaging
16970	2 3/4"	1 3/16"	8 1/16"	Baby Moon	8 of 3/4"	CH	Box of 50
16971	2 3/4"	1 3/16"	8 1/16"	Baby Moon	8 of 3/4"	SS	Box of 50
16972	2 3/4"	1 3/16"	8 1/16"	Baby Moon	8 of 3/4"	CH	BP
16973	2 3/4"	1 3/16"	8 1/16"	Baby Moon	8 of 3/4"	SS	BP
16960	2 3/4"	7/8"	8 3/16"	Conical	8 of 3/4"	CH	Box of 50
16961	2 3/4"	7/8"	8 3/16"	Conical	8 of 3/4"	SS	Box of 50
16962	2 3/4"	7/8"	8 3/16"	Conical	8 of 3/4"	CH	BP
16963	2 3/4"	7/8"	8 3/16"	Conical	8 of 3/4"	SS	BP
17130	2 1/4"	7/8"	8 3/16"	Hubdometer	8 of 3/4"	CH	Box of 50
17131	2 1/4"	7/8"	8 3/16"	Hubdometer	8 of 3/4"	SS	Box of 50
17132	2 1/4"	7/8"	8 3/16"	Hubdometer	8 of 3/4"	CH	BP
17133	2 1/4"	7/8"	8 3/16"	Hubdometer	8 of 3/4"	SS	BP

Rear Hub Cap for Meritor 38000 Axle*

	Height	Side Wall	Inside Diameter	Style	Fit Stud Size	Material	Packaging
16905	2 7/8"	1 1/4"	8"	Baby Moon	Up to 1"	SS	Box of 50
16906	2 7/8"	1 1/4"	8"	Baby Moon	Up to 1"	CH	Box of 50

*CAD drawings are available from Pages 117 - 118.



Rear Hub Cap for Mack 40,000+lb (1998 and Older)*

	Height	Side Wall	Inside Diameter	Style	Fit Stud Size	Material	Packaging
16980	2 11/16"	1"	8 9/16"	Baby Moon	-	CH	Box of 50
16981	2 11/16"	1"	8 9/16"	Baby Moon	-	SS	Box of 50
16982	2 11/16"	1"	8 9/16"	Baby Moon	-	CH	BP
16983	2 11/16"	1"	8 9/16"	Baby Moon	-	SS	BP

Rear Hub Cap for Mack 40,000+lb (1999 and Newer)*

	Height	Side Wall	Inside Diameter	Style	Fit Stud Size	Material	Packaging
16990	2 3/4"	1 1/16"	8 1/2"	Baby Moon	-	CH	Box of 50
16991	2 3/4"	1 1/16"	8 1/2"	Baby Moon	-	SS	Box of 50
16992	2 3/4"	1 1/16"	8 1/2"	Baby Moon	-	CH	BP
16993	2 3/4"	1 1/16"	8 1/2"	Baby Moon	-	SS	BP

*CAD drawings are available from Page 117.



Rear Hub Cap for International* with 8 5/8" Axle**

	Height	Side Wall	Inside Diameter	Style	Fit Stud Size	Material	Packaging
16954	3 1/8"	1 3/8"	8 3/16"	Baby Moon	Up to 1"	CH	Box of 50
16955	3 1/8"	1 3/8"	8 3/16"	Baby Moon	Up to 1"	SS	Box of 50
16956	3 1/8"	1 3/8"	8 3/16"	Baby Moon	Up to 1"	CH	BP
16957	3 1/8"	1 3/8"	8 3/16"	Baby Moon	Up to 1"	SS	BP

Rear Hub Cap for International 4000-Series Trucks*

	Height	Side Wall	Inside Diameter	Style	Fit Stud Size	Material	Packaging
17000	2 1/2"	1 9/16"	6 1/2"	Baby Moon	-	CH	Box of 50
17001	2 1/2"	1 9/16"	6 1/2"	Baby Moon	-	SS	Box of 50
17002	2 1/2"	1 9/16"	6 1/2"	Baby Moon	-	CH	BP
17003	2 1/2"	1 9/16"	6 1/2"	Baby Moon	-	SS	BP

*CAD drawings are available from Page 117.

**16954 through 16957 are designed to fit International Trucks with Extra Long Studs, 8 5/8" Axle.

TRAILER HUB CAPS



Trailer Hub Cap*

	Height	Side Wall	Inside Diameter	Style	Fit Stud Size	Material	Packaging
16700	2 5/8"	1/2"	9 1/4"	Baby Moon	-	CH	Box of 50
16701	2 5/8"	1/2"	9 1/4"	Baby Moon	-	SS	Box of 50
16702	2 5/8"	1/2"	9 1/4"	Baby Moon	-	CH	BP
16703	2 5/8"	1/2"	9 1/4"	Baby Moon	-	SS	BP

ABS Trailer Hub Cap

Description

AC-ABS-6 6 Nuts ABS Trailer Axle Cover, Snap on

Trailer Hub Cap Accessories

Description

16750 Mounting Bracket for Trailer Axle. Mounts 8 1/4" Hub Caps, 16930 and 16931. Installation Instructions on Page 29.

16760 Replacement Clips for Trailer Hub Caps 16700, 16701 (Package of 3)

*CAD drawings are available from Page 117.

MUD FLAP PRODUCTS

Heavy-gauge
spring loaded
Light Bars
and Mud
Flap Hangers
available in OEM
grade, stainless
steel, chrome,
and black
powder coat.



Bolt Patterns

All American Chrome® Mud Flap Hangers come in one of two industry-standard bolt patterns; 1.125" (1^{1/8}") or 2.50" (2^{1/2}"). The term 'bolt pattern' refers to the spacing of the two bolts that extend from the end plate of the product, and are used to secure the product to the frame of the vehicle. Many trucks have pre-drilled holes for mounting Mud Flap Hangers, and the easiest mounting method is to use these existing holes to secure the product to the truck frame. The distance between the bolts is measured between the center of each bolt to the opposite bolt as shown below.

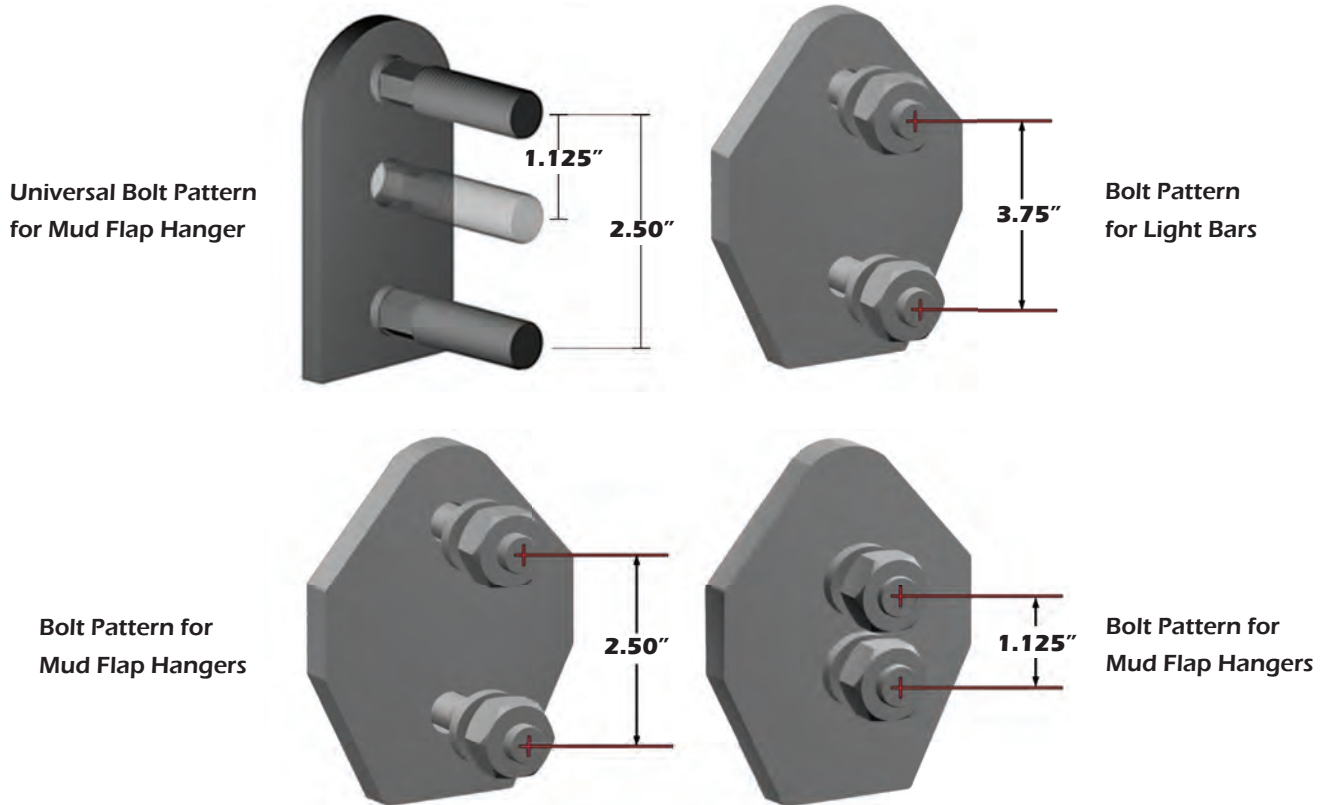

Spring-Loaded vs Standard

American Chrome® Light Bars are available in Standard and Spring-Loaded Configurations. Spring-Loaded Light Bars are designed to bend when hit, and the heavy-duty internal springs snap the unit back into place when the obstruction is clear. Depending on the severity of the impact, the product may show some minor physical damage, but is designed to offer continued service until the unit can be replaced.

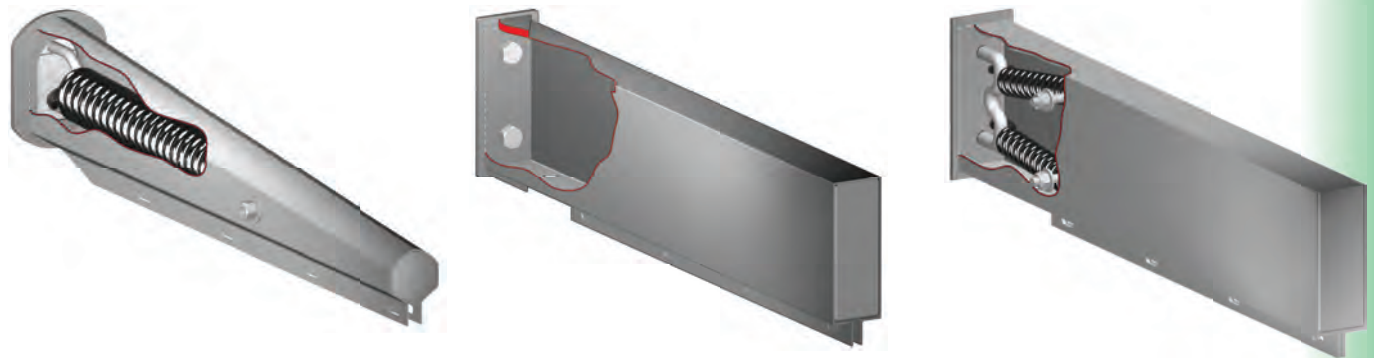

Spring-Loaded Mud Flap Hangers - Spring-Loaded Mud Flap Hangers feature one spring under tension. Spring is powerful enough to return the Hanger to its original position after impact. Constructed of heavy-gauge Stainless Steel.

Standard Light Bars- Standard Light Bars are constructed of heavy-gauge Stainless Steel, with two internal bolts welded to a thick slab steel end plate to provide a secure attachment point.

Spring-Loaded Light Bars - Spring-Loaded Light Bars feature two smaller springs under tension. Springs are powerful enough to return the Light Bar to its original position after impact. Constructed of heavy-gauge Stainless Steel.

Hardware Mount

Using Stainless Steel, the Hardware-Mount-Style Mud Flap Weights are the best option for secure mounting and less chance of breakage.

Hardware Mount -Hardware-Mounted Mud Flap Weights feature several square holes, with carriage bolts going through the weight and the mud flap. The provided washers and nuts are used to complete the assembly. This is a very secure way to mount hardware to a mud flap, and is less prone to breakage due to road debris and hazards.



American Chrome® Mud Flap Weights are available in:

Stainless - American Chrome's Stainless Steel Mud Flap Weights are forged from a massive slab of high-grade stainless steel to resist rust and corrosion. Designed to last.

SuperPremium Chrome - Nothing beats the classic sparkle and shine of genuine chrome, and no chrome finish lasts as long or is as durable as our exclusive SuperPremium Chrome finish. Chrome Mud Flap Hangers are forged from heavy-weight steel for durability.

Weld Stud Mount

The Weld Stud Mount style Mud Flap Weights are designed to be less likely to attract dirt and debris.

Weld Stud Mount - Weld Stud Mount Mud Flap Weights feature three welded studs with threads, located on the rear of the unit. The studs go through the mud flap, and are secured using the provided washers and nuts. This mounting style provides the cleanest look.



MUD FLAP HANGERS



Spring-Loaded Mud Flap Hanger

	Length	Style	Bolt Pattern*	Material	Reflector	Packaging
21930	27"	Straight	1.125"	CH	-	Pair
21932	27"	Straight	1.125"	Black	-	Pair
21954	30"	Straight	2.5"	CH	-	Pair
21960	30"	Straight	2.5"	CH	-	Pair
21961	30"	Straight	2.5"	SS	-	Pair
21962	30"	Straight	2.5"	Black	-	Pair
21963	30"	Straight	2.5"	SS	Yes	Pair
21965	30"	Straight	1.125" & 2.5"	CH	Yes	Pair
21967	30"	Straight	1.125" & 2.5"	SS	Yes	Pair
21969	30"	Straight	1.125" & 2.5"	Black	Yes	Pair
21990	30"	45° Angle	1.125"	CH	-	Pair
21991	30"	45° Angle	1.125"	SS	-	Pair
21992	30"	45° Angle	1.125"	Black	-	Pair
22000	30"	45° Angle	2.5"	CH	-	Pair
22001	30"	45° Angle	2.5"	SS	-	Pair
22002	30"	45° Angle	2.5"	Black	-	Pair
22010	27"	45° Angle	1.125"	CH	-	Pair
22012	27"	45° Angle	1.125"	Black	-	Pair

*See page 41 for information about Bolt Pattern.



Economy-Style Mud Flap Hanger**

	Length	Style	Bolt Pattern*	Material	Packaging
21910	27"	Straight	1.125"	Black	Pair
21911	30"	Double Coil, Straight	2.5"	Black	Pair
21920	30"	45° Angle	2.5"	Black	Pair
21921	30"	Double Coil, 45° Angle	2.5"	Black	Pair

Economy-Style Mud Flap Hanger Kit

Description

21910K	Kit includes Part# 21910 with Mounting Brackets, Hardware and Cotter Pins (Pair).
21920K	Kit includes Part# 21920 with Mounting Brackets, Hardware and Cotter Pins (Pair).
21911K	Kit includes Part# 21911 with Mounting Brackets, Hardware and Cotter Pins (Pair).
21921K	Kit includes Part# 21921 with Mounting Brackets, Hardware and Cotter Pins (Pair).

*See page 41 for information about Bolt Pattern.

**Hangers do not include Mounting Brackets, Hardware and Cotter Pins.

MUD FLAP HANGER PARTS



Mud Flap Hanger Replacement Part

Description

- 21900 Add-On Conspicuity Reflector for all Straight Light Bar and Mud Flap Hanger products (Pair).
- 21905 Add-On Conspicuity Reflector for all 45° Angle Light Bar and Mud Flap Hanger products (Pair).
- 21906 14" Replacement Spring for Spring Loaded Mud Flap Hangers Part# 21930/32, 21960/61/62, 21990/91/92, 22000/01/02, and 22010/12.
- 21925 Cast Steel Mounting Bracket for all Economy-Style Mud Flap hangers (Pair).
- 22055 Snap-In End Cap for Spring Loaded Mud Flap Hanger Part# 21969.

MUD FLAP WEIGHTS

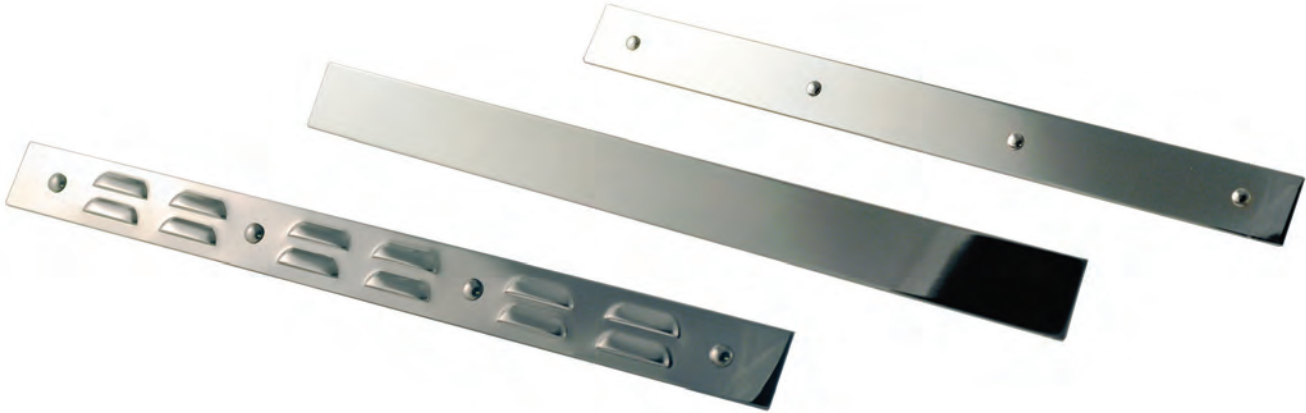

Mud Flap Top Weight

	Length	Width	Mounting*	Cutout	Material	Packaging
14400	24"	2"	Hardware	-	CH	Box of 20
14401	24"	2"	Hardware	-	SS	Box of 20
14402	24"	2"	Hardware	-	CH	BP, Pair
14403	24"	2"	Hardware	-	SS	BP, Pair
14404	24"	2"	Hardware	Louvers	CH	Box of 20
14405	24"	2"	Hardware	Louvers	SS	Box of 20
14406	24"	2"	Hardware	Louvers	CH	BP, Pair
14407	24"	2"	Hardware	Louvers	SS	BP, Pair
14410	24"	2"	Welded Stud	-	CH	Box of 20
14411	24"	2"	Welded Stud	-	SS	Box of 20
14412	24"	2"	Welded Stud	-	CH	BP, Pair
14413	24"	2"	Welded Stud	-	SS	BP, Pair

*Top and Bottom Weights sold in Pairs as BP only.

*See page 42 for information about Mounting.

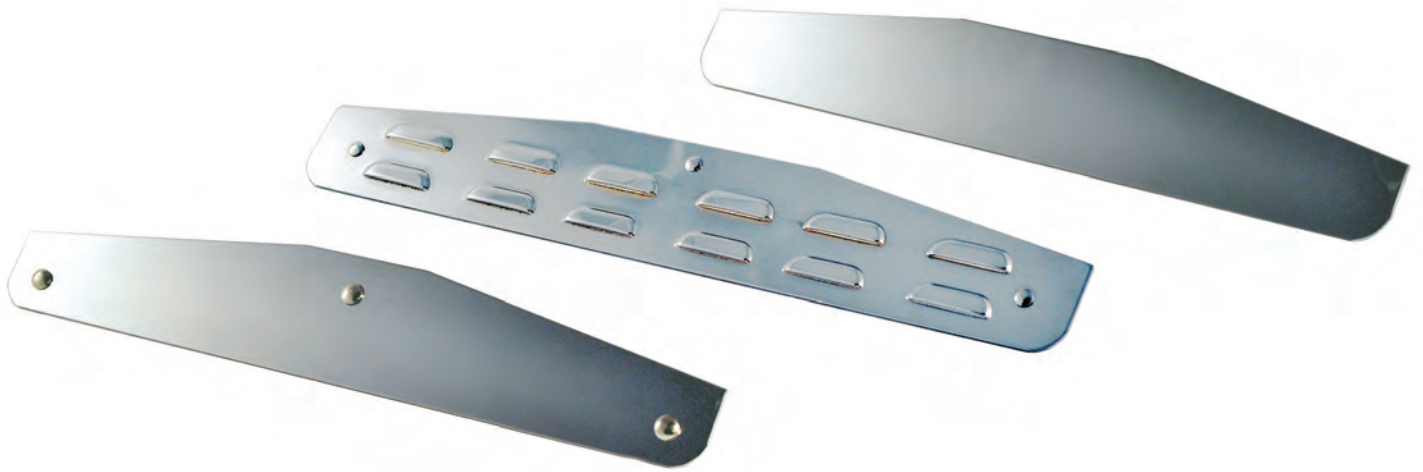

Mud Flap Bottom Weight

	Length	Width	Mounting*	Cutout	Style	Material	Packaging
14440	10"	3"	Welded Stud	-	Bottom	CH	Box of 20
14450	12"	3"	Welded Stud	-	Bottom	CH	Box of 20
14460	14"	3"	Welded Stud	-	Bottom	CH	Box of 20
14470	16"	3"	Welded Stud	-	Bottom	CH	Box of 20
14480	18"	3"	Welded Stud	-	Bottom	CH	Box of 20
14481	18"	3"	Welded Stud	-	Bottom	SS	Box of 20
14482	18"	3"	Welded Stud	-	Bottom	CH	BP, Pair
14483	18"	3"	Welded Stud	-	Bottom	SS	BP, Pair
14490	24"	4"	Welded Stud	-	Bottom	CH	Box of 20
14491	24"	4"	Welded Stud	-	Bottom	SS	Box of 20
14492	24"	4"	Welded Stud	-	Bottom	CH	BP, Pair
14493	24"	4"	Welded Stud	-	Bottom	SS	BP, Pair
14510	24"	4"	Hardware	-	Bottom	CH	Box of 20
14511	24"	4"	Hardware	-	Bottom	SS	Box of 20
14512	24"	4"	Hardware	-	Bottom	CH	BP, Pair
14513	24"	4"	Hardware	-	Bottom	SS	BP, Pair
14530	24"	4"	Hardware	Louvers	Bottom	CH	Box of 20
14531	24"	4"	Hardware	Louvers	Bottom	SS	Box of 20
14532	24"	4"	Hardware	Louvers	Bottom	CH	BP, Pair
14533	24"	4"	Hardware	Louvers	Bottom	SS	BP, Pair



Mud Flap Bottom Weight with Cutout

	Length	Width	Mounting*	Cutout	Style	Material	Packaging
14550	24"	4"	Welded Stud	Freightliner	Bottom	CH	Box of 20
14551	24"	4"	Welded Stud	Freightliner	Bottom	SS	Box of 20
14552	24"	4"	Welded Stud	Freightliner	Bottom	CH	BP, Pair
14553	24"	4"	Welded Stud	Freightliner	Bottom	SS	BP, Pair
14560	24"	4"	Welded Stud	International	Bottom	CH	Box of 20
14562	24"	4"	Welded Stud	International	Bottom	CH	BP, Pair
14580	24"	4"	Welded Stud	Mack	Bottom	CH	Box of 20
14582	24"	4"	Welded Stud	Mack	Bottom	CH	BP, Pair
14600	24"	4"	Welded Stud	Sterling	Bottom	CH	Box of 20
14601	24"	4"	Welded Stud	Sterling	Bottom	SS	Box of 20
14602	24"	4"	Welded Stud	Sterling	Bottom	CH	BP, Pair
14603	24"	4"	Welded Stud	Sterling	Bottom	SS	BP, Pair
14610	24"	4"	Welded Stud	Volvo	Bottom	CH	Box of 20
14612	24"	4"	Welded Stud	Volvo	Bottom	CH	BP, Pair
14620	24"	4"	Welded Stud	Western Star	Bottom	CH	Box of 20
14622	24"	4"	Welded Stud	Western Star	Bottom	CH	BP, Pair
22580	16"	11"	Welded Stud	Mack Logo	Bottom	CH	Box of 20

*Top and Bottom Weights sold in Pairs as BP only.

*See page 42 for information about Mounting.

ANTI-SAIL BRACKETS



Anti-Sail Bracket

	Length	Height	Degree	Material	Packaging
22160	24"	17"	-	CH	Box of 20
22170	24"	21"	-	CH	Box of 20
22171	24"	21"	-	SS	Box of 20
22174	24"	17, 21"	45° *	CH	Pair

*45° Anti-Sail Bracket - Fits All 45° Mud Flap Hangers.

LIGHT BARS



One-Piece Deluxe Light Bar

	Length	Height	Width	Number of Lights	Type of Lights	Shape of Lights	Bolt Pattern*	Material
21611	95 3/16"	6 1/2"	2 1/2"	6	Red, Incandescent	6.5" Oval	3.75"	SS
21613	95 3/16"	6 1/2"	2 1/2"	6	Red, LED	6.5" Oval	3.75"	SS
21621	95 3/16"	6 1/2"	2 1/2"	6	Not Included	6.5" Oval	3.75"	SS
21631	95 3/16"	6 1/2"	2 1/2"	6	Red, Incandescent	5" Rect	3.75"	SS
21633	95 3/16"	6 1/2"	2 1/2"	6	Red, LED	5" Rect	3.75"	SS
21641	95 3/16"	6 1/2"	2 1/2"	6	Not Included	5" Rect	3.75"	SS
21651	95 3/16"	6 1/2"	2 1/2"	6	Red, Incandescent	4" Round	3.75"	SS
21653	95 3/16"	6 1/2"	2 1/2"	6	Red, LED	4" Round	3.75"	SS
21661	95 3/16"	6 1/2"	2 1/2"	6	Not Included	4" Round	3.75"	SS

Mounting Brackets for One-Piece Deluxe Light Bar

Description

21600	Mounting Brackets for One-Piece Deluxe Light Bar. Not Included in Kit (Set of 2)
-------	--

*See page 41 for information about Bolt Pattern.



Two-Piece Spring-Loaded Light Bar **

	Length	Height	Width	Number of Lights	Type of Lights	Shape of Lights	Bolt Pattern*	Material
21801	30 3/4"	6 3/8"	2 3/8"	6	Red, Incandescent	6.5" Oval	3.75"	SS
21805	30 3/4"	6 3/8"	2 3/8"	6	Red, LED	6.5" Oval	3.75"	SS
21811	30 3/4"	6 3/8"	2 3/8"	6	Not Included	6.5" Oval	3.75"	SS
21821	30 3/4"	6 3/8"	2 3/8"	6	Red, Incandescent	5" Rect	3.75"	SS
21825	30 3/4"	6 3/8"	2 3/8"	6	Red, LED	5" Rect	3.75"	SS
21831	30 3/4"	6 3/8"	2 3/8"	6	Not Included	5" Rect	3.75"	SS
21840	30 3/4"	6 3/8"	2 3/8"	6	Red, Incandescent	4" Round	3.75"	CH
21841	30 3/4"	6 3/8"	2 3/8"	6	Red, Incandescent	4" Round	3.75"	SS
21843	30 3/4"	6 3/8"	2 3/8"	6	Red, LED	4" Round	3.75"	CH
21845	30 3/4"	6 3/8"	2 3/8"	6	Red, LED	4" Round	3.75"	SS
21850	30 3/4"	6 3/8"	2 3/8"	6	Not Included	4" Round	3.75"	CH
21851	30 3/4"	6 3/8"	2 3/8"	6	Not Included	4" Round	3.75"	SS

Replacement Part for Spring-Loaded Light Bars

Description

21907 6.5" Replacement Spring for Spring-Loaded Light Bars.

*See page 41 for information about Bolt Pattern. **Two-Piece Light Bars are sold in pairs

LIGHT BRACKETS



Light Bracket for Oval Lights

	Number of Lights	Type of Lights	Shape	Material
21401	1	Not Included	6.5" Oval	SS
21403	1	Red, Incandescent	6.5" Oval	SS
21431	2	Not Included	6.5" Oval	SS
21433	2	Red, Incandescent	6.5" Oval	SS
21461	3	Not Included	6.5" Oval	SS
21463	3	Red, Incandescent	6.5" Oval	SS

Light Bracket for Rectangular Lights

	Number of Lights	Type of Lights	Shape	Material
21411	1	Not Included	5" Rectangle	SS
21413	1	Red, Incandescent	5" Rectangle	SS
21415	1	Red, LED	5" Rectangle	SS
21441	2	Not Included	5" Rectangle	SS
21443	2	Red, Incandescent	5" Rectangle	SS
21445	2	Red, LED	5" Rectangle	SS
21471	3	Not Included	5" Rectangle	SS
21473	3	Red, Incandescent	5" Rectangle	SS
21475	3	Red, LED	5" Rectangle	SS



Light Bracket with Round Lights

	Number of Lights	Type of Lights	Shape of Lights	Material
21421	1	Not Included	4" Round	SS
21423	1	Red, Incandescent	4" Round	SS
21425	1	Red, LED	4" Round	SS
21451	2	Not Included	4" Round	SS
21453	2	Red, Incandescent	4" Round	SS
21455	2	Red, LED	4" Round	SS
21481	3	Not Included	4" Round	SS
21483	3	Red, Incandescent	4" Round	SS
21485	3	Red, LED	4" Round	SS

REPLACEMENT LIGHTS & GROMMETS



Replacement Lights and Grommets

Description

60002	6.5" Oval Red Incandescent Light
60003	6.5" Oval Red LED Light
60008	6.5" Oval Red Incandescent Light with Rubber Grommet
60009	6.5" Oval Red LED Light with Rubber Grommet
60022	5" Rectangular Red Incandescent Light
60023	5" Rectangular Red LED Light
60028	5" Rectangular Red Incandescent Light with Rubber Grommet
60029	5" Rectangular Red LED Light with Rubber Grommet
60042	4" Round Red Incandescent Light
60043	4" Round Red LED Light
60048	4" Round Red Incandescent Light with Rubber Grommet
60049	4" Round Red LED Light with Rubber Grommet
68900	6.5" Oval Rubber Grommet
68901	5" Rectangular Rubber Grommet
68902	4" Rectangular Rubber Grommet



NUT COVERS

North America's
largest
selection of
OEM-grade
lug nut covers.
ABS chrome,
stainless steel,
and chrome
steel available
in all sizes and
styles.

ABS Chrome Nut Cover

Internal Threads - Threads molded into the body of the ABS Nut Cover mate with the threads on the exposed stud above the lug nut. Typically it requires at least 3 complete turns to assure a tight fit.

Lug Nut - ABS Nut Covers come in two basic sizes. 33mm Nut Covers fit lug nuts on hub piloted wheels, and 1.5" Nut Covers fit lug nuts on stud piloted wheels. The amount of exposed thread above the lug nut is the only consideration when choosing Twist-On or Push-On styles.

The Twist-On style provides the most secure attachment, but Push-On is useful when limited amount of thread is available.

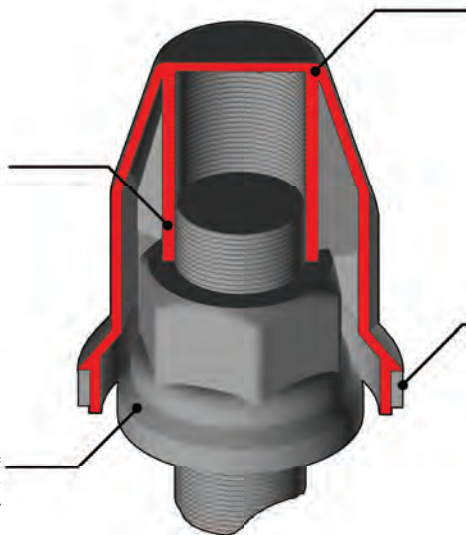

Twist-On Style

ABS Body - Nut Covers are molded from a high-strength automotive plastic called ABS or PC ABS. This material is impervious to rust or corrosion, and will never chip or peel. ABS offers extreme durability and resistance to the elements, at an affordable price.

Infinity ABS Nut Covers are ideal for vocational applications, where wheels will be exposed to extreme environments.

Notched Flange - Twist-On ABS Lug Nut Covers featuring the notched flange design are designed specifically for use with our line of ABS Hub Covers. The notches work in concert with the locking mechanism designed into the ABS Hub Covers to provide a secure fit. ABS Nut Covers with these notched flanges will work with all standard Twist-On applications as well, and are available as a decorative enhancement on some of our ABS Nut Covers.

Push-On ABS Nut Covers are available with both notched and smooth flanges, and work equally well with any of our ABS Hub Covers.

Internal Ribs - Ribs molded into the body of the ABS Nut Cover provide a 'friction fit' against the flat sides of the lug nuts. Repeatedly installing and removing the ABS Nut Cover can wear down the surface and reduce the tension against the lug nut, resulting in lost or loose nut covers.

Lug Nut - ABS Nut Covers come in two basic sizes. 33mm Nut Covers fit lug nuts on hub piloted wheels, and 1.5" Nut Covers fit lug nuts on stud piloted wheels. The amount of exposed thread above the lug nut is the only consideration when choosing Twist-On or Push-On styles.

The Twist-On style provides the most secure attachment, but Push-On is useful when limited amount of thread is available.

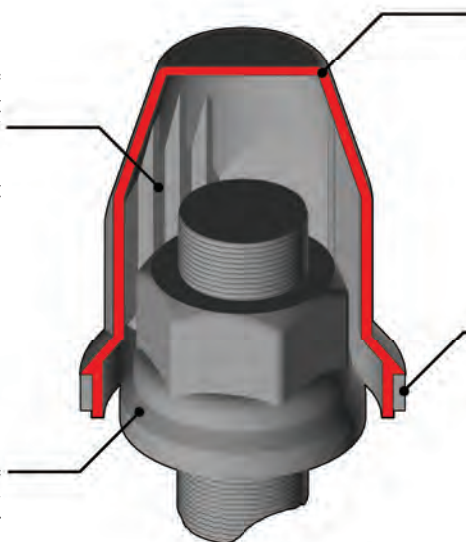

Push-On Style

ABS Body - Nut Covers are molded from a high-strength automotive plastic called ABS or PC ABS. This material is impervious to rust or corrosion, and will never chip or peel. ABS offers extreme durability and resistance to the elements, at an affordable price.

Flange - ABS Nut Covers are typically offered "with Flange" and "without Flange". 33mm lug nuts for Hub-Piloted wheels require a Nut Cover with flange for a proper fit. 1.5" lug nuts do not require a flanged Nut Cover, but they are available as a decorative option.

Chrome & Stainless Steel Nut Cover

Stud - Using a properly designed and installed Lug Nut Cover not only beautifies the wheels, it protects the threads on the stud from rust, corrosion, and dirt, making it easier to remove and maintain the wheels.

Dimple - There are usually three dimples placed around the exterior of the Nut Cover. These dimples provide the 'friction-fit' that keeps the Nut Cover tightly in place. The size of a nut cover is determined by measuring from the inside surface of the dimple to the opposite 'flat' surface of the Nut Cover.

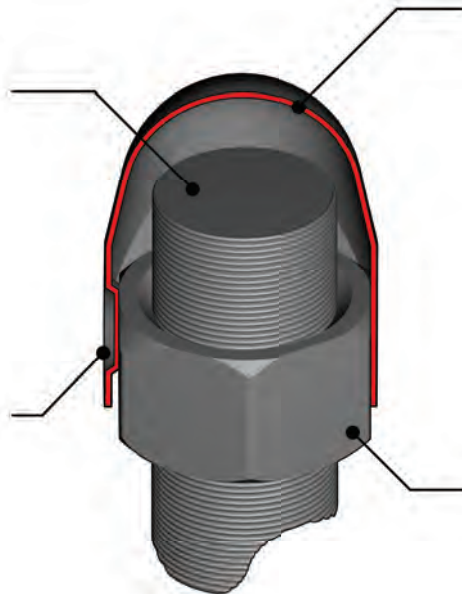

SuperPremium Chrome - Quality Lug Nut Covers are manufactured from heavy-gauge steel, then plated using our unique SuperPremium® Chrome plating process. Our OEM-grade Nut Covers are designed to provide years of service without rusting or corroding, and the thick steel resists dents and dings better than the cheap imitators.

Many of our popular models are also available in heavy-duty 304 stainless steel, which is guaranteed never to rust.

No Flange - 1.5" Lug nuts (used on stud-piloted wheels) do not have an integral flange washer, and do not need a flanged Nut Cover for a proper fit. However, many customer like the look of flanged Nut Covers, and these are available as a decorative option on many of our models.

Without Flange

Stud - Using a properly designed and installed Lug Nut Cover not only beautifies the wheels, it protects the threads on the stud from rust, corrosion, and dirt, making it easier to remove and maintain the wheels.

Dimple - There are usually three dimples placed around the exterior of the Nut Cover. These dimples provide the 'friction-fit' that keeps the Nut Cover tightly in place. The size of a nut cover is determined by measuring from the inside surface of the dimple to the opposite 'flat' surface of the Nut Cover.

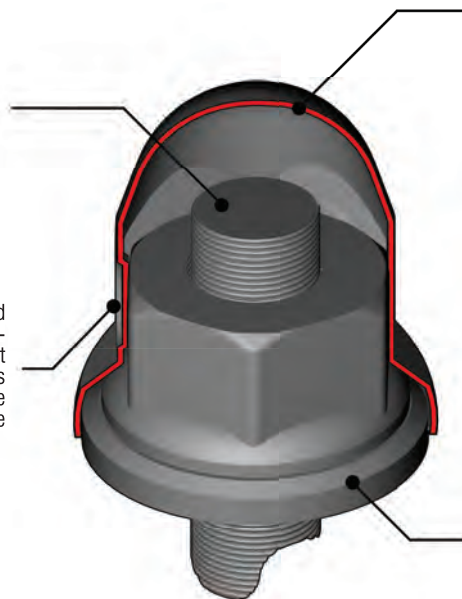

304 Stainless Steel - Our OEM-grade Nut Covers are designed to provide years of service without rusting or corroding, and the thick steel resists dents and dings better than the cheap imitators. 304 stainless is guaranteed never to rust.

Many of our popular models are also available in SuperPremium Chrome for those looking for a classic chrome look.

With Flange - 33mm Lug Nuts (used on hub-piloted wheels) have an integral flange washer at the base. This feature requires a flange on the Nut Cover installed.

With Flange

ABS CHROME NUT COVERS



18000



18011



18020



18010



18100, 18200



18120, 18220



18300



18350



18210



18110



18170

1 1/2" ABS Chrome Nut Cover

	Diameter	Height	Application	Flange	Reflector	Packaging
18000	1 1/2"	2 3/4"	Push-on	Yes	-	Box of 250
18002	1 1/2"	2 3/4"	Push-on	Yes	-	BP of 8
18004	1 1/2"	2 3/4"	Push-on	Yes	-	Box of 100
18011	1 1/2"	2 3/4"	Push-on	-	-	Box of 250
18013	1 1/2"	2 3/4"	Push-on	-	-	BP
18015	1 1/2"	2 3/4"	Push-on	-	-	Box of 100
18020	1 1/2"	2 3/4"	Push-on	Yes	Amber	Box of 250
18022	1 1/2"	2 3/4"	Push-on	Yes	Amber	BP
18024	1 1/2"	2 3/4"	Push-on	Yes	Amber	Box of 100
18030	1 1/2"	2 3/4"	Push-on	Yes	Red	Box of 250
18032	1 1/2"	2 3/4"	Push-on	Yes	Red	BP
18034	1 1/2"	2 3/4"	Push-on	Yes	Red	Box of 100
18040	1 1/2"	2 3/4"	Push-on	Yes	Blue	Box of 250
18042	1 1/2"	2 3/4"	Push-on	Yes	Blue	BP
18044	1 1/2"	2 3/4"	Push-on	Yes	Blue	Box of 100
18050	1 1/2"	2 3/4"	Push-on	Yes	Purple	Box of 250
18052	1 1/2"	2 3/4"	Push-on	Yes	Purple	BP
18054	1 1/2"	2 3/4"	Push-on	Yes	Purple	Box of 100

1 1/2" ABS Chrome Nut Cover for ABS Axle Cover Sets

	Diameter	Height	Application	Flange	Reflector	Packaging
18010	1 1/2"	2 3/4"	Push-on	-	-	Box of 250
18012	1 1/2"	2 3/4"	Push-on	-	-	BP
18014	1 1/2"	2 3/4"	Push-on	-	-	Box of 100

33mm ABS Chrome Nut Cover

	Diameter	Height	Application	Flange	Reflector	Packaging
18100	33mm	2 7/8"	Twist-on	Yes	-	Box of 250
18102	33mm	2 7/8"	Twist-on	Yes	-	BP
18104	33mm	2 7/8"	Twist-on	Yes	-	Box of 100
18120	33mm	2 7/8"	Twist-on	Yes	Amber	Box of 250
18122	33mm	2 7/8"	Twist-on	Yes	Amber	BP
18124	33mm	2 7/8"	Twist-on	Yes	Amber	Box of 100
18130	33mm	2 7/8"	Twist-on	Yes	Red	Box of 250
18132	33mm	2 7/8"	Twist-on	Yes	Red	BP
18134	33mm	2 7/8"	Twist-on	Yes	Red	Box of 100
18140	33mm	2 7/8"	Twist-on	Yes	Blue	Box of 250
18142	33mm	2 7/8"	Twist-on	Yes	Blue	BP
18144	33mm	2 7/8"	Twist-on	Yes	Blue	Box of 100
18150	33mm	2 7/8"	Twist-on	Yes	Purple	Box of 250
18152	33mm	2 7/8"	Twist-on	Yes	Purple	BP
18154	33mm	2 7/8"	Twist-on	Yes	Purple	Box of 100
18200	33mm	2 7/8"	Push-on	Yes	-	Box of 250
18202	33mm	2 7/8"	Push-on	Yes	-	BP
18204	33mm	2 7/8"	Push-on	Yes	-	Box of 100
18220	33mm	2 7/8"	Push-on	Yes	Amber	Box of 250
18222	33mm	2 7/8"	Push-on	Yes	Amber	BP
18224	33mm	2 7/8"	Push-on	Yes	Amber	Box of 100
18230	33mm	2 7/8"	Push-on	Yes	Red	Box of 250
18232	33mm	2 7/8"	Push-on	Yes	Red	BP
18324	33mm	2 7/8"	Push-on	Yes	Red	Box of 100
18240	33mm	2 7/8"	Push-on	Yes	Blue	Box of 250
18242	33mm	2 7/8"	Push-on	Yes	Blue	BP
18244	33mm	2 7/8"	Push-on	Yes	Blue	Box of 100

33mm ABS Chrome Nut Cover

	Diameter	Height	Application	Flange	Reflector	Packaging
18250	33mm	2 7/8"	Push-on	Yes	Purple	Box of 250
18252	33mm	2 7/8"	Push-on	Yes	Purple	BP
18254	33mm	2 7/8"	Push-on	Yes	Purple	Box of 100
18300	33mm	2 7/8"	Push-on	Yes	-	Box of 250
18302	33mm	2 7/8"	Push-on	Yes	-	BP

Tall-Boy ABS Chrome Nut Cover

	Diameter	Height	Application	Flange	Reflector	Packaging
18350	33mm	3 5/16"	Push-on	Yes	No	Box of 200
18352	33mm	3 5/16"	Push-on	Yes	No	BP

Bullet-Style ABS Chrome Nut Cover

	Diameter	Height	Application	Flange	Reflector	Packaging
18210	33mm	2 1/2"	Push-on	Yes	No	Box of 250
18212	33mm	2 1/2"	Push-on	Yes	No	BP
18214	33mm	2 1/2"	Push-on	Yes	No	Box of 100

ABS Black Chrome Nut Cover

	Diameter	Height	Application	Flange	Reflector	Packaging
18110	33mm	2 7/8"	Twist-on	Yes	-	Box of 250

5-Spoke ABS Chrome Nut Cover

	Diameter	Height	Application	Flange	Reflector	Packaging
18170	33mm	2 7/8"	Twist-on	Yes	-	Box of 250

NUT COVERS



17500



17506



17510



17520



17570



17580



17610



17650



17640



17550



17590



17600, 17800, 17810



17660



17700



17850



17806

7/8" - 1 3/4" Nut Cover

	Diameter	Height	Flange	Reflector	Material	Packaging
17500	7/8"	1 3/16"	-	-	CH	Box of 100
17501	7/8"	1 3/16"	-	-	SS	Box of 100
17502	7/8"	1 3/16"	-	-	CH	BP
17503	7/8"	1 3/16"	-	-	SS	BP
17506	1"	1 5/16"	-	-	CH	Box of 100
17508	1"	1 3/8"	Yes	-	CH	Box of 100
17510	1 1/16"	1 1/8"	Yes	-	CH	Box of 100
17511	1 1/16"	1 1/8"	-	-	SS	Box of 100
17512	1 1/16"	1 1/8"	-	-	CH	BP
17513	1 1/16"	1 1/8"	-	-	SS	BP
17515	1 1/16"	1 9/16"	-	-	SS	Box of 100
17520	1 1/8"	1 5/8"	Yes	-	CH	Box of 100
17522	1 1/8"	1 5/8"	Yes	-	CH	BP
17530	1 1/8"	1 3/16"	-	-	CH	Box of 100
17531	1 1/8"	1 3/16"	-	-	SS	Box of 100
17532	1 1/8"	1 3/16"	-	-	CH	BP
17533	1 1/8"	1 3/16"	-	-	SS	BP
17570	1 1/2"	1 5/8"	-	-	CH	Box of 500
17571	1 1/2"	1 5/8"	-	-	SS	Box of 500
17572	1 1/2"	1 5/8"	-	-	CH	BP
17573	1 1/2"	1 5/8"	-	-	SS	BP
17574	1 1/2"	1 5/8"	-	-	CH	Box of 100
17575	1 1/2"	1 5/8"	-	-	SS	Box of 100
17580	1 1/2"	1 15/16"	Yes	-	CH	Box of 500
17581	1 1/2"	1 15/16"	Yes	-	SS	Box of 500
17582	1 1/2"	1 15/16"	Yes	-	CH	BP
17583	1 1/2"	1 15/16"	Yes	-	SS	BP
17980	1 3/4"	1 15/16"	Yes	-	CH	Box of 100
17981	1 3/4"	1 15/16"	Yes	-	SS	Box of 100

1 1/2" - 1 3/4" Nut Cover with Reflectors

	Diameter	Height	Flange	Reflector	Material	Packaging
17610	1 1/2"	2"	-	Amber	CH	Box of 500
17612	1 1/2"	2"	-	Amber	CH	BP
17620	1 1/2"	2"	-	Red	CH	Box of 500
17622	1 1/2"	2"	-	Red	CH	BP
17630	1 1/2"	2"	-	Blue	CH	Box of 500
17632	1 1/2"	2"	-	Blue	CH	BP
17640	1 1/2"	2"	-	Purple	CH	Box of 500
17642	1 1/2"	2"	-	Purple	CH	BP
17650	1 3/4"	1 7/8"	-	-	CH	Box of 100
17652	1 3/4"	1 7/8"	-	-	CH	BP

1 1/4" Nut Cover for Dayton Wheels

	Diameter	Height	Flange	Reflector	Material	Packaging
17540	1 1/4"	1 7/8"	-	-	CH	Box of 100
17541	1 1/4"	1 7/8"	-	-	SS	Box of 100
17542	1 1/4"	1 7/8"	-	-	CH	BP
17543	1 1/4"	1 7/8"	-	-	SS	BP
17550	1 1/4"	2"	Yes	-	CH	Box of 100
17551	1 1/4"	2"	Yes	-	SS	Box of 100
17552	1 1/4"	2"	Yes	-	CH	BP
17553	1 1/4"	2"	Yes	-	SS	BP

1 1/2" Bullet-Style Nut Cover

	Diameter	Height	Flange	Reflector	Material	Packaging
17590	1 1/2"	2"	-	-	CH	Box of 500
17591	1 1/2"	2"	-	-	SS	Box of 500
17592	1 1/2"	2"	-	-	CH	BP
17593	1 1/2"	2"	-	-	SS	BP
17594	1 1/2"	2"	-	-	CH	Box of 100
17595	1 1/2"	2"	-	-	SS	Box of 100
17600	1 1/2"	2"	Yes	-	CH	Box of 500
17601	1 1/2"	2"	Yes	-	SS	Box of 500
17602	1 1/2"	2"	Yes	-	CH	BP
17603	1 1/2"	2"	Yes	-	SS	BP

30mm - 32mm Nut Covers with Flange

	Diameter	Height	Flange	Reflector	Material	Packaging
17660	30mm	50mm	Yes	-	CH	Box of 500
17661	30mm	50mm	Yes	-	SS	Box of 500
17662	30mm	50mm	Yes	-	CH	BP
17663	30mm	50mm	Yes	-	SS	BP
17670	30mm	50mm	Yes	Amber	CH	Box of 500
17700	32mm	54mm	Yes	-	CH	Box of 500
17701	32mm	54mm	Yes	-	SS	Box of 500
17702	32mm	54mm	Yes	-	CH	BP
17703	32mm	54mm	Yes	-	SS	BP
17710	32mm	54mm	Yes	-	CH	Box of 500

33mm Bullet-Style Nut Cover

	Diameter	Height	Flange	Reflector	Material	Packaging
17800	33mm	50mm	Yes	-	CH	Box of 500
17801	33mm	50mm	Yes	-	SS	Box of 500
17802	33mm	50mm	Yes	-	CH	BP
17803	33mm	50mm	Yes	-	SS	BP
17804	33mm	50mm	Yes	-	CH	Box of 100
17805	33mm	50mm	Yes	-	SS	Box of 100
17810	33mm	56mm	Yes	-	CH	Box of 100
17811	33mm	56mm	Yes	-	SS	Box of 100

33mm Nut Cover with Reflector

	Diameter	Height	Flange	Reflector	Material	Packaging
17850	33mm	46mm	Yes	Amber	CH	Box of 100
17852	33mm	46mm	Yes	Amber	CH	BP
17860	33mm	46mm	Yes	Red	CH	Box of 100
17862	33mm	46mm	Yes	Red	CH	BP
17870	33mm	46mm	Yes	Blue	CH	Box of 100
17872	33mm	46mm	Yes	Blue	CH	BP
17880	33mm	46mm	Yes	Purple	CH	Box of 100
17882	33mm	46mm	Yes	Purple	CH	BP

33mm Tall-Boy Nut Cover

	Diameter	Height	Flange	Reflector	Material	Packaging
17806	33mm	64mm	Yes	No	CH	Box of 100
17807	33mm	64mm	Yes	No	SS	Box of 100
17808	33mm	64mm	Yes	No	CH	BP
17809	33mm	64mm	Yes	No	SS	BP

CHROME BOLT COVERS



Chrome Bolt Cover

	Diameter	Height	Flange	Reflector	Material	Packaging
17500	7/8"	1 1/8"	-	-	CH	Box of 100
18500	7/16"	5/8"	-	-	CH	Box of 100
18510	1/2"	11/16"	-	-	CH	Box of 100
18520	9/16"	11/16"	-	-	CH	Box of 100
18530	5/8"	3/4"	-	-	CH	Box of 100
18550	3/4"	15/16"	-	-	CH	Box of 100
18560	11/16"	7/8"	-	-	CH	Box of 100
18570	15/16"	1 3/8"	-	-	CH	Box of 100
18540	3/4"	1 1/4"	Yes	-	CH	Box of 100

NUT COVER INSTALLATION TOOLS



Nut Cover Installation Wrench

Description

- 18400 Nut Cover Wrench for installation or removal of 1.5" Nut Covers. Soft vinyl coating on handles and jaws protects against damage to nut cover surface.
- 18410 Adjustable Nut Cover Wrench for installation or removal of Covers from 7/8" to 1.5". Soft vinyl coating on handles and jaws protects against damage to nut cover surface.

ABS Nut Cover Installation Bar

Description

- 15990 High-Strength Polymer Lug Nut Cover Bar for Installation and Removal of 33mm and 1.5" ABS Nut Covers.
- 15991 Installation Adapter for Hex Style ABS Chrome Nut Covers part# 18170, used with 15990. Insert 15991 into the end of 15990 to install the Hex Style ABS Chrome Nut Covers (18700) in 5-Spoke Axle Cover Kits (15300 and 15800).

QUARTER FENDERS

Beautiful, rugged Deluxe and Economy models in mirror finish using heavy-gauge stainless steel. Triangle and tube mount styles available.



Product Information - Quarter Fenders

Fender Size

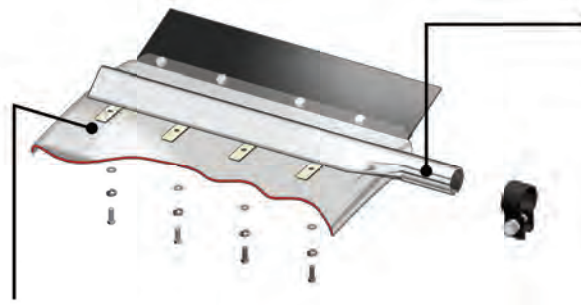

Triangle Mount

Quarter Fenders with the Deluxe Triangle Mount provide a unique and classy look for your quarter fenders. Deluxe Mounts feature internal hardware mounts for a clean, contemporary look. The hardware and mounts are manufactured exclusively from heavy-gauge 304 Stainless Steel

Rubber Grommet - Three (3) or Four (4) thick rubber grommets provides vibration isolation and extends the life of the quarter fender

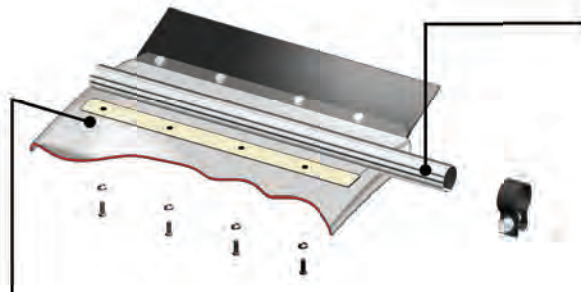

Tube Mount

The standard Tube Mount is used on our Premium and Economy lines. The tube and hardware is manufactured exclusively from top-grade stainless steel, and features a unique internal mounting system that eliminates the sight of u-bolts and other external hardware.

Rubber Grommet - A thick rubber grommet provides vibration isolation and extends the life of the quarter fender



There will be Four (4) or Three (3) Mounting holes on the blanks depending on quarter fender models.

QUARTER FENDERS

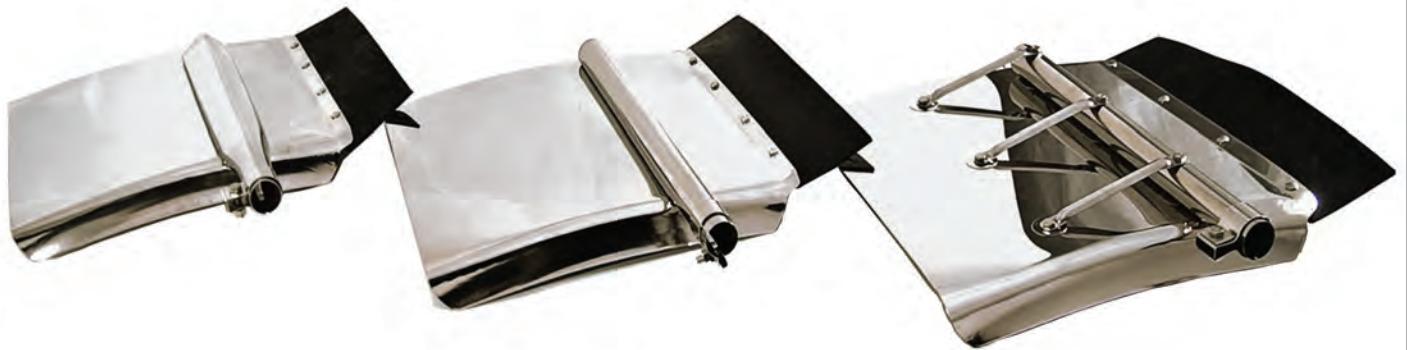

Deluxe Quarter Fender Kit with Triangle Mount

	Length	Width	Material	Mount	Packaging
19420	24"	24"	SS	Triangle	Set of 2
19425	27"	24"	SS	Triangle	Set of 2

Economy Quarter Fender Kit with Tube Mount

	Length	Width	Material	Mount	Packaging
19401	24"	24"	SS	Tube	Set of 2
19406	27"	24"	SS	Tube	Set of 2
19407	24"	24"	SS	Tube w/ support straps	Set of 2
19412	27"	24"	SS	Tube w/ support straps	Set of 2

QUARTER FENDER PARTS



Universal and Tandem Quarter Fender Mounting Brackets

Description

- 14315 8" x 1 15/16" Socket Mount with Hardware (Not included with other kits).
- 14317 8" x 2" Socket Mount with Hardware (Not included with other kits).
- 14360 Universal Tandem Mounting Bracket with 4" Offset. Black Powder Coat Finish (Pair).
- 14361 Universal Tandem Mounting Bracket with 6" Offset. Black Powder Coat Finish (Pair).
- 14362 Universal Tandem Mounting Bracket with 8" Offset. Black Powder Coat Finish (Pair).

Steel Clamp for Tube/Triangle Mount

Description

- 19350 Heavy-Duty Stainless Steel Clamp with Hardware for All Quarter Fender Models (Pair).

Top Mud Flap for Quarter Fender

Description

- 19360 6" x 24" Black Rubber Top Mud Flap with Hardware (Pair).

SIMULATOR PRODUCTS

Full wheel stainless steel simulator kits. High gloss stainless finish complete with all popular styles of hub caps, axle covers and nut covers.



Lug Nuts

Lug nuts come in a variety of sizes and types, which affects the way accessory products attach to the wheel. The most common sizes are 33mm (for Hub-Piloted wheels) and 1.5" (for Stud-Piloted wheels). Our Simulators and Simulator sets typically require the removal of only half of the lug nuts, with the others remaining in place to secure the wheel.

Front Wheel Simulator

Wheel Simulators are available individually, or as part of a complete 'Simulator Set' which includes the Simulator, Nut Covers, and Axle Covers. All Simulators and Simulator sets can be ordered as 'Hub-Piloted' or 'Stud-Piloted', which affects how the product is secured to the wheel. It is important to properly identify your wheel type when ordering these products to ensure an accurate and secure fit.

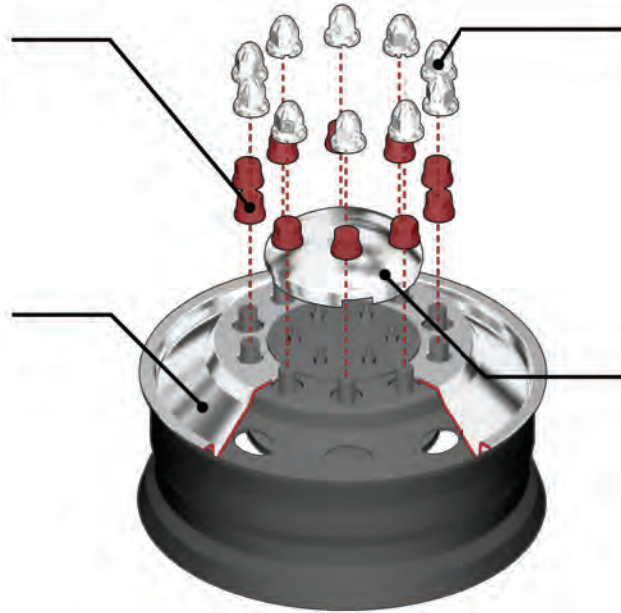

Lug Nuts

Lug nuts come in a variety of sizes and types, which affects the way accessory products attach to the wheel. The most common sizes are 33mm (for Hub-Piloted wheels) and 1.5" (for Stud-Piloted wheels). Our Simulators and Simulator sets typically require the removal of only half of the lug nuts, with the others remaining in place to secure the wheel.

Rear Wheel Simulator

Wheel Simulators are available individually, or as part of a complete 'Simulator Set' which includes the Simulator, Nut Covers, and Axle Covers. All Simulators and Simulator sets can be ordered as 'Hub-Piloted' or 'Stud-Piloted', which affects how the product is secured to the wheel. It is important to properly identify your wheel type when ordering these products to ensure an accurate and secure fit.

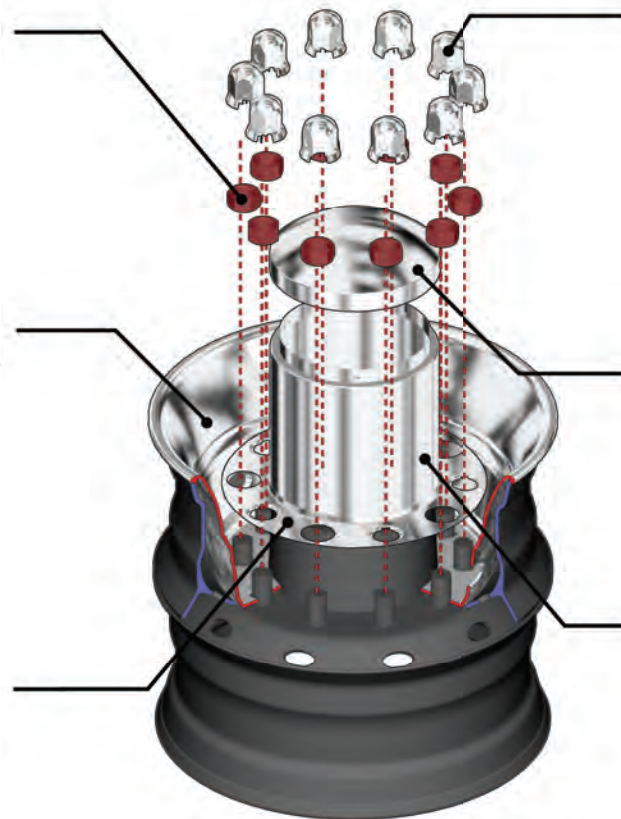

Beauty Ring

Beauty Rings are included with all of our Simulator Sets, and are available individually for a custom configuration. They are available in 1-piece, integrated designs, or in the more common 2-piece design. All beauty rings are sold as either 'Hub-Piloted' or 'Stud-Piloted' configurations. It is important that the correct item be used to ensure a secure and accurate fit.

Nut Covers

Size varies by application. Hub-Piloted Wheels typically use 33mm Nut Covers, and Stud-Piloted wheels use 1.5" Nut Covers. All of our Wheel Simulator kits include 8 or 10 nut covers, depending on the model. Nut Covers, in a variety of unique styles, can be ordered separately for a completely custom configuration. Nut Covers compatible with Simulators and Simulator Sets are typically available in Chrome and 304 stainless.

Hub Cap

Standard 'Baby Moon' style Hub caps are included with all of our Simulator Sets. A variety of other styles and types, compatible with our Simulators and Simulator sets, are available individually, for a completely custom look.

Nut Covers

Size varies by application. Hub-Piloted Wheels typically use 33mm Nut Covers, and Stud-Piloted wheels use 1.5" Nut Covers. All of our Wheel Simulator kits include 8 or 10 nut covers, depending on the model. Nut Covers, in a variety of unique styles, can be ordered separately for a completely custom configuration. Nut Covers compatible with Simulators and Simulator Sets are typically available in Chrome and 304 stainless.

Hub Cap

When ordering Simulators or Simulator sets, you can specify either a 1-piece or 2-piece design. The 1-piece designs have an integrated hub cap, which is non-removable. The 2-piece designs feature a removable cap which allows access to the hub components while the Simulator remains installed.

Axle Cover

Axle Covers are included as part of the complete Simulator Kit, or can be purchased separately for a custom configuration. All Axle Covers come as either 'Hub-Piloted' or 'Stud-Piloted', and must be ordered correctly for a proper fit.

LIGHT-DUTY SIMULATOR SETS



16" Light-Duty Wheel Simulator Sets* - 2 Axles

Description

- 11701 16" Wheel Simulator Set - All in One 'Snap-In' style, front and rear, 8 Integrated Lug Nut Covers with 4 Hand Holes, stainless steel.
- 11711 16" Wheel Simulator Set - For Ford F450/E-53 Super-Duty Dual Wheels, 10 Individual Lug Nut Covers, 4 Hand Holes, stainless steel.
- 11721 16" Wheel Simulator Set - Universal Fit. 1-Piece Hub Cover Integrated with 8 Nut Covers, 4 Hand Holes, stainless steel, axle mounting bracket included.

19.5" Wheel Simulator Sets* - 2 Axles

Description

- 11751 19.5" Wheel Simulator Set - For General Motors Trucks. 275mm Bolt Circle, 8 Lugs, 4 Hand Holes, 30mm Nut Covers. Over-the-Lug mounting, stainless steel.
- 11753 19.5" Wheel Simulator Set - For Ford and International Trucks. 275mm Bolt Circle, 8 Lugs, 4 Hand Holes, 32mm Nut Covers. Over-the-Lug mounting, stainless steel.
- 11755 19.5" Wheel Simulator Set - Universal Fit. 275mm Bolt Circle, 8 Lugs, 4 Hand Holes, 33mm Nut Covers. Over-the-Lug mounting, stainless steel.
- 11761 19.5" Wheel Simulator Set - For Light/Medium Duty Truck and International TerraStar™. 285mm Bolt Circle, 10 Lugs, 5 Hand Holes, 33mm Nut Covers. Over-the-Lug mounting, stainless steel.
- 11771 19.5" Wheel Simulator Set - For General Motors Trucks. 275mm Bolt Circle, 8 Lugs, 4 Hand Holes, 30mm Nut Covers. Under-the-Lug mounting, stainless steel.
- 11775 19.5" Wheel Simulator Set - Universal Fit. 275mm Bolt Circle, 8 Lugs, 4 Hand Holes, 33mm Nut Covers. Under-the-Lug mounting, stainless steel.

*Sets include two (2) front wheel simulators and two (2) rear wheel simulators.
All Simulator Sets/Kits are Stainless Steel.

WHEEL SIMULATOR KITS



Stud-Piloted Front Wheel Simulator Kit *

	Fits Wheel Size	Bolt Circle	Lug Holes	Hand Holes	Nut Size	Material
86001	22.5" x 7.5"	11.25"	10	2	1.5"	SS
86011	22.5" x 7.5"	11.25"	10	5	1.5"	SS
86021	22.5" x 8.25"	11.25"	10	2	1.5"	SS
86031	22.5" x 8.25"	11.25"	10	5	1.5"	SS
86041	24.5" x 8.25"	11.25"	10	2	1.5"	SS
86051	24.5" x 8.25"	11.25"	10	5	1.5"	SS

Hub-Piloted Front Wheel Simulator Kit *

	Fits Wheel Size	Bolt Circle	Lug Holes	Hand Holes	Nut Size	Material
86003	22.5" x 7.5"	11.25"	10	2	33mm	SS
86013	22.5" x 7.5"	11.25"	10	5	33mm	SS
86023	22.5" x 8.25"	11.25"	10	2	33mm	SS
86033	22.5" x 8.25"	11.25"	10	5	33mm	SS
86043	24.5" x 8.25"	11.25"	10	2	33mm	SS
86053	24.5" x 8.25"	11.25"	10	5	33mm	SS

*All Simulator Kits are Stainless Steel. Sold in sets of two (2), complete for one (1) axle.
CAD drawings are available from Page 121.



Stud-Piloted Rear Wheel Simulator Kit* w/ Non-Removable Cap

	Fits Wheel Size	Bolt Circle	Lug Holes	Hand Holes	Nut Size	Material
86061	22.5" x 7.5"	11.25"	10	2	1.5"	SS
86071	22.5" x 7.5"	11.25"	10	5	1.5"	SS
86081	22.5" x 8.25"	11.25"	10	2	1.5"	SS
86091	22.5" x 8.25"	11.25"	10	5	1.5"	SS
86101	24.5" x 8.25"	11.25"	10	2	1.5"	SS
86111	24.5" x 8.25"	11.25"	10	5	1.5"	SS

Hub-Piloted Rear Wheel Simulator Kit* w/ Non-Removable Cap

	Fits Wheel Size	Bolt Circle	Lug Holes	Hand Holes	Nut Size	Material
86063	22.5" x 7.5"	11.25"	10	2	33mm	SS
86073	22.5" x 7.5"	11.25"	10	5	33mm	SS
86083	22.5" x 8.25"	11.25"	10	2	33mm	SS
86093	22.5" x 8.25"	11.25"	10	5	33mm	SS
86103	24.5" x 8.25"	11.25"	10	2	33mm	SS
86113	24.5" x 8.25"	11.25"	10	5	33mm	SS

*All Simulator Kits are Stainless Steel. Sold in sets of two (2), complete for one (1) axle.
CAD drawings are available from Page 122.



Stud-Piloted Rear Wheel Simulator Kit* w/ Removable Cap

	Fits Wheel Size	Bolt Circle	Lug Holes	Hand Holes	Nut Size	Material
86121	22.5" x 7.5"	11.25"	10	2	1.5"	SS
86131	22.5" x 7.5"	11.25"	10	5	1.5"	SS
86141	22.5" x 8.25"	11.25"	10	2	1.5"	SS
86151	22.5" x 8.25"	11.25"	10	5	1.5"	SS
86161	24.5" x 8.25"	11.25"	10	2	1.5"	SS
86171	24.5" x 8.25"	11.25"	10	5	1.5"	SS

Hub-Piloted Rear Wheel Simulator Kit* w/ Removable Cap

	Fits Wheel Size	Bolt Circle	Lug Holes	Hand Holes	Nut Size	Material
86123	22.5" x 7.5"	11.25"	10	2	33mm	SS
86133	22.5" x 7.5"	11.25"	10	5	33mm	SS
86143	22.5" x 8.25"	11.25"	10	2	33mm	SS
86153	22.5" x 8.25"	11.25"	10	5	33mm	SS
86163	24.5" x 8.25"	11.25"	10	2	33mm	SS
86173	24.5" x 8.25"	11.25"	10	5	33mm	SS

*All Simulator Kits are Stainless Steel. Sold in sets of two (2), complete for one (1) axle.
CAD drawings are available from Page 122.

FRONT WHEEL SIMULATORS



Stud-Piloted Front Wheel Simulator*

	Fits Wheel Size	Bolt Circle	Lug Holes	Hand Holes	Material
84001	22.5" x 7.5"	11.25"	10	2	SS
84011	22.5" x 7.5"	11.25"	10	5	SS
84031	22.5" x 8.25"	11.25"	10	2	SS
84041	22.5" x 8.25"	11.25"	10	5	SS
84061	24.5" x 8.25"	11.25"	10	2	SS
84071	24.5" x 8.25"	11.25"	10	5	SS

Hub-Piloted Front Wheel Simulator*

	Fits Wheel Size	Bolt Circle	Lug Holes	Hand Holes	Material
84003	22.5" x 7.5"	11.25"	10	2	SS
84013	22.5" x 7.5"	11.25"	10	5	SS
84033	22.5" x 8.25"	11.25"	10	2	SS
84043	22.5" x 8.25"	11.25"	10	5	SS
84063	24.5" x 8.25"	11.25"	10	2	SS
84073	24.5" x 8.25"	11.25"	10	5	SS

*All Simulators are Stainless Steel. CAD drawings are available from Page 121.

REAR WHEEL SIMULATORS



Stud-Piloted Rear Wheel Simulator*

	Fits Wheel Size	Bolt Circle	Lug Holes	Hand Holes	Vent Cut	Material
85001	22.5" x 7.5"	11.25"	10	2	-	SS
85011	22.5" x 7.5"	11.25"	10	5	-	SS
85031	22.5" x 8.25"	11.25"	10	2	-	SS
85041	22.5" x 8.25"	11.25"	10	5	-	SS
85061	24.5" x 8.25"	11.25"	10	2	-	SS
85071	24.5" x 8.25"	11.25"	10	5	-	SS

Hub-Piloted Rear Wheel Simulator*

	Fits Wheel Size	Bolt Circle	Lug Holes	Hand Holes	Vent Cut	Material
85003	22.5" x 7.5"	11.25"	10	2	Small	SS
85013	22.5" x 7.5"	11.25"	10	5	-	SS
85033	22.5" x 8.25"	11.25"	10	2	-	SS
85043	22.5" x 8.25"	11.25"	10	5	-	SS
85063	24.5" x 8.25"	11.25"	10	2	-	SS
85073	24.5" x 8.25"	11.25"	10	5	-	SS

*All Simulators are Stainless Steel. CAD drawings are available from Page 122.

WHEEL COVERS

Front and Rear
Wheel Covers
manufactured
from heavy-
gauge premium
stainless steel.



Stud-Piloted - Products designated for "stud-piloted" wheels typically have ten (10) lug holes. Five (5) of the holes are 1.25" in diameter and have a slight taper that conforms to the shape of the lug nut. The other five (5) lug holes are 1.75" in diameter and are sized to slip over the existing lug nuts without removal.

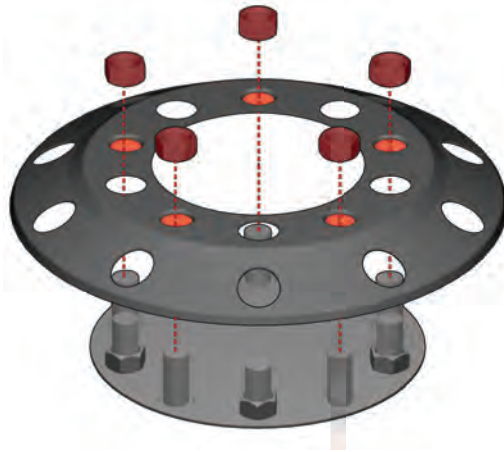

Installation Tip - Our products are designed to install easily, without removing the wheel or all fasteners. Simply remove five (5) of the lug nuts, slip the Wheel Cover over the wheel, and secure with the lug nuts you removed earlier.

To prevent damaging the product, avoid over-torquing the lug nuts. Do not exceed the wheel manufacturer's recommendations.

Hub-Piloted - Products designated for "hub-piloted" wheels typically have ten (10) lug holes. Five (5) of the holes are 1" in diameter to fit over the lug bolt only, and five (5) lug holes are 1.88" in diameter and are sized to slip over the existing lug nuts without removal.

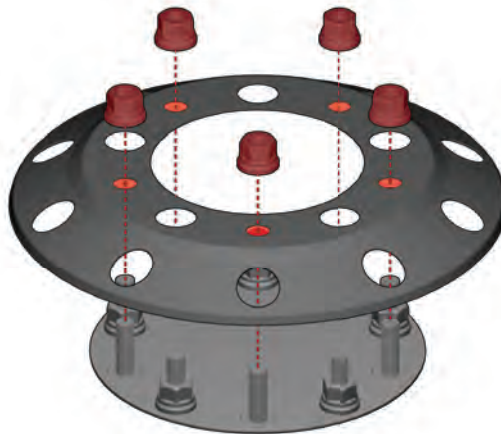

Installation Tip - Our products are designed to install easily, without removing the wheel or all fasteners. Simply remove five (5) of the lug nuts, slip the Wheel Cover over the wheel, and secure with the lug nuts you removed earlier.

To prevent damaging the product, avoid over-torquing the lug nuts. Do not exceed the wheel manufacturer's recommendations.

FRONT WHEEL COVER KITS



Stud-Piloted Front Wheel Cover Kit*

	Fits Wheel Size	Lug Holes	Hand Holes	Nut Cover Size	Hub Cap Style	Material
87001	22.5"	(5) 1.25", (5) 1.75"	2	1.5"	4-Notch, Conical	SS
87011	22.5"	(5) 1.25", (5) 1.75"	2	1.5"	4-Notch, Baby Moon	SS
87021	22.5"	(5) 1.25", (5) 1.75"	2	1.5"	5-Notch, Baby Moon	SS
87031	22.5"	(5) 1.25", (5) 1.75"	2	1.5"	6-Notch, Baby Moon	SS
87041	22.5"	(5) 1.25", (5) 1.75"	2	1.5"	6-Notch, Baby Moon, Uneven Cut	SS
87051	22.5"	(5) 1.25", (5) 1.75"	5	1.5"	4-Notch, Conical	SS
87061	22.5"	(5) 1.25", (5) 1.75"	5	1.5"	4-Notch, Baby Moon	SS
87071	22.5"	(5) 1.25", (5) 1.75"	5	1.5"	5-Notch, Baby Moon	SS
87081	22.5"	(5) 1.25", (5) 1.75"	5	1.5"	6-Notch, Baby Moon	SS
87091	22.5"	(5) 1.25", (5) 1.75"	5	1.5"	6-Notch, Baby Moon, Uneven Cut	SS

*Complete for one (1) axle.



Hub-Piloted Front Wheel Cover Kit*

	Fits Wheel Size	Lug Holes	Hand Holes	Nut Cover Size	Hub Cap Style	Material
87003	22.5"	(5) 1", (5) 1.88"	2	33mm	4-Notch, Conical	SS
87013	22.5"	(5) 1", (5) 1.88"	2	33mm	4-Notch, Baby Moon	SS
87023	22.5"	(5) 1", (5) 1.88"	2	33mm	5-Notch, Baby Moon	SS
87033	22.5"	(5) 1", (5) 1.88"	2	33mm	6-Notch, Baby Moon	SS
87043	22.5"	(5) 1", (5) 1.88"	2	33mm	6-Notch, Baby Moon, Uneven Cut	SS
87053	22.5"	(5) 1", (5) 1.88"	5	33mm	4-Notch, Conical	SS
87063	22.5"	(5) 1", (5) 1.88"	5	33mm	4-Notch, Baby Moon	SS
87073	22.5"	(5) 1", (5) 1.88"	5	33mm	5-Notch, Baby Moon	SS
87083	22.5"	(5) 1", (5) 1.88"	5	33mm	6-Notch, Baby Moon	SS
87093	22.5"	(5) 1", (5) 1.88"	5	33mm	6-Notch, Baby Moon, Uneven Cut	SS

*Complete for one (1) axle.

FRONT WHEEL COVERS



Stud-Piloted Front Wheel Cover

	Fits Wheel Size	Hand/Vent Holes	Material
80021	20"	10	SS
80031	22.5"	2	CH
80041	22.5"	2	SS
80051	22.5"	5	CH
80061	22.5"	5	SS
80071	22.5"	10	CH
80081	22.5"	10	SS
80121	24.5"	5	SS
80131	24.5"	10	CH
80141	24.5"	10	SS



Hub-Piloted Front Wheel Cover

	Fits Wheel Size	Hand/Vent Holes	Material
80023	20"	10	SS
80033	22.5"	2	CH
80043	22.5"	2	SS
80053	22.5"	5	CH
80063	22.5"	5	SS
80073	22.5"	10	CH
80083	22.5"	10	SS
80093	24.5"	2	CH
80113	24.5"	5	CH
80123	24.5"	5	SS
80133	24.5"	10	CH
80143	24.5"	10	SS

MIRRORS

OEM-grade mirrors available in heavy-gauge chrome and stainless steel.



MIRRORS



Convex Mirrors

	Size	Mounting	Material	Package
19001	5"	Center Mount	SS	BP
19002	5"	Center Mount	Steel, Black	BP
19020	6"	Center Mount	CH	BP
19021	6"	Center Mount	SS	BP
19022	6"	Center Mount	Steel, Black	BP
19040	7"	Center Mount	CH	BP
19041	7"	Center Mount	SS	BP
19042	7"	Center Mount	Steel, Black	BP
19050	7"	Offset Mount	CH	BP
19051	7"	Offset Mount	SS	BP
19052	7"	Offset Mount	Steel, Black	BP
19060	8"	Center Mount	CH	BP
19061	8"	Center Mount	SS	BP
19062	8"	Center Mount	Steel, Black	BP
19070	8"	Offset Mount	CH	BP
19071	8"	Offset Mount	SS	BP
19072	8"	Offset Mount	Steel, Black	BP
19075	8.5"	Offset Mount w/ Cone Back	SS	BP



West Coast Mirrors

	Size	Light / Reflector	Heat	Material	Package
19090	6" x 16"	--	--	Aluminum	Display Box
19081	6" x 16"	--	--	SS	Display Box
19101	6" x 16"	Amber Light	Heated	SS	Display Box
19111	6" x 16"	Amber Reflector	--	SS	Display Box
19113	7" x 16"	--	Heated	SS	Display Box

West Coast Mirror w/Convex Bottom

	Size	Light / Reflector	Heat	Material	Package
19121	6" x 16"	--	--	SS	Display Box



Heavy Duty OEM-Style West Coast Mirrors

	Size	Light / Reflector	Heat	Back Shape	Material	Package
19083	7" x 16"	--	--	Plain	SS	Display Box
19103	7" x 16"	Amber Light	Heated	--	SS	Display Box
19131	7" x 16"	--	--	Ribbed	SS	Display Box
19132	7" x 16"	--	--	Ribbed	Steel, Black	Display Box
19141	7" x 16"	--	Heated	Bubble	SS	Display Box
19142	7" x 16"	--	--	Bubble	Steel, Black	Display Box
19151	7" x 16"	--	--	Pyramid	SS	Display Box
19152	7" x 16"	--	--	Pyramid	Steel, Black	Display Box

Bracket and Mount for Mirrors

Description

19200 Replacement 'L' Bracket for Convex Mirrors

19210 Stainless Steel Universal Tripod Mount for use w/Convex Mirror Head. Includes 3" Steel & Rubber Washers to prevent damage to fiberglass fenders. Main Mast adjusts from 22" to 31" high. Top Support Arm adjusts from 14" to 21" in length. Non-adjustable 3rd Arm.

OTHER PRODUCTS

American Chrome® also offers a wide variety of other products to include: Air Horns, Bumper Guides, Boot Brushes, Dash Fans, Grease Guns, Hydraulic Bottle Jacks, License Frame Products, Lights, U-Joints, and Retail Displays.



AIR HORNS



Heavy-Duty Train Horn

Description

- 23450 Triple-Tone Train Horn. L-shaped mount. In-line Solenoid Valve. Solid Copper. Chrome Finish.
- 23456 Triple-Tone Train Horn, Economy Style with 6.25" Bell. In-line Solenoid Valve. 15.5"L x 12"W. Chrome Finish.
- 23460 Triple-Tone Train Horn with Two (2) 7.25" & One (1) 6" Bell. Solid Brass Trumpets and Heavy-Duty Cast Metal Base & Support. In-line Solenoid Valve. 18"L x 12"H. Chrome Finish. 120dB at 15psi, up to 150dB. Chrome Finish.
- 23476 Quad-Tone Train Horn Economy Style with 6.25" Bell. In-line Solenoid Valve. 15.5"L x 12"W. Chrome Finish.
- 23480 Quad-Tone Train Horn with Four Solid Brass Trumpets and Heavy-Duty Cast Metal Base & Support. In-line Solenoid Valve. 16"L x 12"W x 13"H. Chrome Finish.



Single-Tone Air Horn

Description

- 23461 28" Single-Tone Air Horn with a 8.5"x4.75" Rectangular Bell. Solid Brass Trumpet and Cast Metal Base & Support. In-line Solenoid Valve. 37.5"L x 5"H. Chrome Finish.
- 23462 24" Single-Tone Air Horn with a 6" Bell. Solid Brass Trumpet and Cast Metal Base & Support. In-line Solenoid Valve. 24"L x 6.5"H. Chrome Finish.
- 23463 24" Single-Tone Air Horn with a 6" Bell. Solid Brass Trumpet and Cast Metal Base & Support. In-line Solenoid Valve. 24"L x 6.5"H. Black Finish.
- 23465 37" Single-Tone Air Horn with a 7" Bell. Solid Brass Trumpet and Cast Metal Base & Support. In-line Solenoid Valve. 37"L x 7"H. Chrome Finish.

Dual-Tone Air Horn

Description

- 23451 Dual-Tone Air Horn with Two (2) 6" Bells. Solid Brass Trumpets and Cast Metal Base. In-line Solenoid Valve. 12"L x 3 3/4"H. Chrome Finish.

Quad-Tone Air Horn

Description

- 23453 Quad-Tone Air Horn with Four (4) 3.5" Bells. Solid Brass Trumpets and Cast Metal Base. In-line Solenoid Valve. 12"L x 7"H. Chrome Finish.



Air Horn Replacement Kits

Description

23481 Solenoid Valve

23483 Repair Kit for 23451. Kit Contains new diaphragm and hardware.

23484 Repair Kit for 23452. Kit Contains new diaphragm and hardware.

23485 Repair Kit for 23453. Kit Contains new diaphragm, spring, and hardware.

23486 Repair Kit for 23461. Kit Contains new diaphragm and hardware.

23488 Repair Kit for 23463. Kit Contains new diaphragm, spring, and hardware.

23490 Repair Kit for 23460, 23462, 23465. Kit Contains new diaphragm, spring, and hardware.

AIR HORN COVERS



Air Horn Covers*

	Fits Bell Size	Shape	Bracket	Material	Package
23300	3" to 3.5"	Round	Welded	CH	Each
23310	3.75" to 4"	Round	Welded	CH	Each
23320	5.5" to 6"	Round	Welded	CH	Each
23321	5.5" to 6"	Round	Welded	SS	Each
23340	6.25" to 7"	Round	Welded	CH	Each
23341	6.25" to 7"	Round	Welded	SS	Each
23350	6.25" to 7"	Round	Riveted	CH	Each
23360	7.25" to 7.5"	Round	Welded	CH	Each
23361	7.25" to 7.5"	Round	Welded	SS	Each
23370	7.25" to 7.5"	Round	Riveted	CH	Each
23380	7.75" to 8"	Round	Welded	CH	Each
23400	4.5" x 8.5"	Rectangular 'Hadley' Style	Riveted	CH	Each
23411	4 5/8" x 7 3/8"	Rectangular 'Grover' Style	Welded	SS	Each

*Air Horn Covers are also available in Blister Packaging (BP).

BUMPER GUIDES



Standard Bumper Guides

	Length	Mount	Lens	Material	Package
18600	38"	Flat Clamp	Amber	CH	Pair
18601	38"	Flat Clamp	Amber	SS	Pair
18650	38"	G-Clamp	Amber	CH	Pair
18651	38"	G-Clamp	Amber	SS	Pair
18700	48"	Flat Clamp	Amber	CH	Pair
18701	48"	Flat Clamp	Amber	SS	Pair
18750	48"	G-Clamp	Amber	CH	Pair
18751	48"	G-Clamp	Amber	SS	Pair
18800	52"	Flat Clamp	Amber	CH	Pair
18801	52"	Flat Clamp	Amber	SS	Pair
18850	52"	G-Clamp	Amber	CH	Pair
18851	52"	G-Clamp	Amber	SS	Pair



Deluxe Bumper Guides

	Length	Mount	Lens	Material	Package
18604	38"	Flat Clamp	Amber	CH	Pair
18605	38"	Flat Clamp	Amber	SS	Pair
18654	38"	G-Clamp	Amber	CH	Pair
18655	38"	G-Clamp	Amber	SS	Pair
18704	48"	Flat Clamp	Amber	CH	Pair
18705	48"	Flat Clamp	Amber	SS	Pair
18754	48"	G-Clamp	Amber	CH	Pair
18755	48"	G-Clamp	Amber	SS	Pair
18804	52"	Flat Clamp	Amber	CH	Pair
18805	52"	Flat Clamp	Amber	SS	Pair
18854	52"	G-Clamp	Amber	CH	Pair
18855	52"	G-Clamp	Amber	SS	Pair

BUMPER GUIDE PARTS



Bumper Guide Replacement Parts

Description

18940	Standard Amber Lens, Set of 2
18941	Standard Red Lens, Set of 2
18942	Standard Blue Lens, Set of 2
18945	Deluxe Amber Lens, Set of 2
18946	Deluxe Red Lens, Set of 2
18947	Deluxe Blue Lens, Set of 2
18960	Repair Kit for Standard & Deluxe Model. Includes, Sockets, Bulb and Wiring Harness
18970	Standard Threaded Collar, CH
18971	Standard Threaded Collar, SS
18972	Deluxe Threaded Collar, CH
18973	Deluxe Threaded Collar, SS
18980	12v Replacement Bulb for Standard or Deluxe Bumper Guide, Set of 2
18990	Washer for 18970/18971
18900	Flat Clamp for Bumper Guide, All Models, CH
18910	G-Clamp for Bumper Guide, All Models, SS

BOOT BRUSH, POGO STICK & PIN PULLER



Boot Brush

Description

23800 Boot Brush with Tough Nylon Bristles and Aluminum Casing 7.5" L x 2" H - Black

Pogo Stick

Description

23730 Pogo Stick- 40" Spring-Loaded, Chrome

Pin Puller 5th Wheel

Description

23640 5th Wheel Pin Puller, Chrome

DECORATIVE HARDWARE & PLACARDS



Decorative Hardware

Description

23620 Chrome Decorative Acorn Nut

23630 Chrome Decorative Bullet



Haz-Mat Placards

Description

22403 1-Piece Haz-Mat Placard Mount w/ 15 Aluminum Placards

ELECTRIC DASH FANS



Electric Dash Fans

Description

- 22440 12-V, 2-Speed Fan with Efficient Permanent Magnet Motor. Sturdy Steel Base for Easy Mounting. Chrome Finish. Rated for 500 Hours MTBF.
- 22445 12-V, OEM-Style 2-Speed Electric Fan. Features our Exclusive Heavy-Duty Electric Motor with Copper Windings for Power, and Quality Sealed Bearings for Long Life and Quiet Operation. Exclusive Cast Steel Base for Rugged Reliability. Chrome Finish. Rated for 5000 Hours MTBF.
- 22450 24-V, OEM-Style 2-Speed Electric Fan. Features Our Exclusive Heavy-Duty Electric Motor with Copper Windings for Power, and Quality Sealed Bearings for Long Life and Quiet Operation. Exclusive Cast Steel Base for Rugged Reliability. Chrome Finish. Rated for 5000 Hours MTBF.

GREASE GUNS



Grease Guns

Description

- 70001 Grease Gun - Heavy Duty, Lever Action, Includes 6" Metal extension & 12" Vinyl Whip Hose.
- 70002 Grease Gun - Compact "Tool Box" size, Includes 3 oz. Grease Cartridge.
- 70003 Suction Gun for Draining Gear Cases, One Pint Capacity with 12" Hose.

HYDRAULIC BOTTLE JACKS



Hydraulic Bottle Jacks

Description

- 23700 12-Ton Hydraulic Bottle Jack with 2-pc Handle.
- 23705 12-Ton 'Low-Boy' Hydraulic Bottle Jack with 2-pc Handle.
- 23710 20-Ton Hydraulic Bottle Jack with 2-pc Handle.
- 23715 20-Ton 'Low-Boy' Hydraulic Bottle Jack with 2-pc Handle.
- 23720 32-Ton Hydraulic Bottle Jack with 2-pc Handle.
- 23725 32-Ton 'Low-Boy' Hydraulic Bottle Jack with 2-pc Handle.

Hydraulic Bottle Jack Repair Kits

Description

- 23701 12-Ton Repair Kit
- 23711 20-Ton Repair Kit
- 23721 32-Ton Repair Kit

LICENSE FRAMES



License Frame

Description

- 20010 Chain-Style Heavy-Duty Zinc-Cast License Frame
- 20020 Narrow-Style Heavy-Duty Zinc-Cast License Frame
- 20030 Twisted-Style Heavy-Duty Zinc-Cast License Frame
- 20040 Fat Bottom-Style Heavy-Duty Zinc-Cast License Frame

REAR LICENSE PANELS

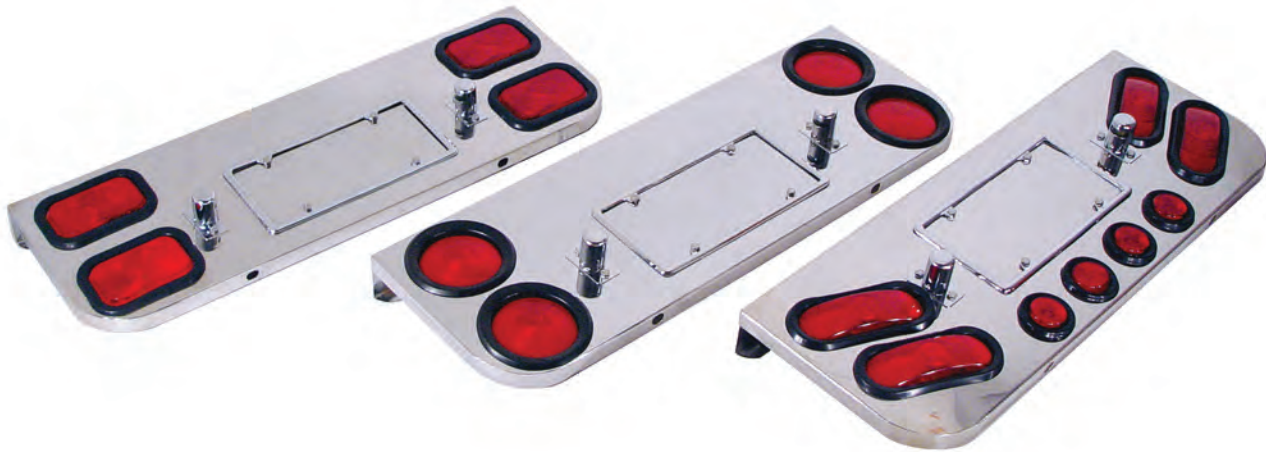

Rear License Panels

	Number of Lights	Type of Lights	Length	Height	Light Shape	Material
21300	4	Incandescent	33 7/8"	12"	4" Round	CH
21301	4	Incandescent	33 7/8"	12"	4" Round	SS
21305	4	LED	33 7/8"	12"	4" Round	SS
21311	4	Incandescent	33 7/8"	12"	5" Rectangle	SS
21315	4	LED	33 7/8"	12"	5" Rectangle	SS
21321	4	Incandescent	33 7/8"	12"	6.5" Oval	SS
21325	4	LED	33 7/8"	12"	6.5" Oval	SS
21330	4	Not Included	33 7/8"	12"	4" Round	SS
21331	4	Not Included	33 7/8"	12"	4" Round	SS
21341	4	Not Included	33 7/8"	12"	4" Round	SS
21351	4	Not Included	33 7/8"	12"	6.5" Oval	SS
21361	8	Incandescent	33 7/8"	12"	4 x 6.5" Oval, 4 x 2" Round	SS
21365	8	LED	33 7/8"	12"	4 x 6.5" Oval, 4 x 2" Round	SS
21371	8	Not Included	33 7/8"	12"	4 x 6.5" Oval, 4 x 2" Round	SS

License Plate Light

Description

69950 Replacement License Plate Lights.

LICENSE PLATE HOLDERS



License Plate Holders

	Length	Height	Mounts	Lights	License	Frames	Light Shape	Material
20101	14"	8"	-	-	1	-	-	SS
20103	14"	8"	-	-	1	1	-	SS
20111	26"	8"	-	-	2	-	-	SS
20113	26"	8"	-	-	2	2	-	SS
20121	39"	8"	-	-	3	-	-	SS
20123	39"	8"	-	-	3	3	-	SS
20130	20"	8"	2	-	1	-	Rectangular	CH
20132	20"	8"	2	2	1	1	Rectangular	CH
20200	18"	10"	2	-	1	-	Rectangular	CH
20202	18"	10"	2	2	1	1	Rectangular	CH
20210	27"	10"	2	-	2	-	Rectangular	CH
20212	27"	10"	2	2	2	2	Rectangular	CH
20131	20"	8"	2	-	1	-	Rectangular	SS
20133	20"	8"	2	2	1	1	Rectangular	SS
20141	32"	8"	2	-	2	-	Rectangular	SS
20143	32"	8"	2	2	2	2	Rectangular	SS

PERMIT HOLDERS



Permit Holders

	Length	Height	Mounts	Material
19901	18"	5"	Rigid	SS
19911	18"	5"	Hinged	SS
19921	24"	5"	Rigid	SS
19931	24"	5"	Hinged	SS
19941	30"	5"	Rigid	SS
19951	30"	5"	Hinged	SS
19961	36"	5"	Hinged	SS

LIGHTS



Lights 2", 4" and 5"

Description

64988	2" Round Incandescent Light w/Red Lens
64989	2" Round LED Light w/Red Lens
60040	4" Round Incandescent Light w/Amber Lens
60041	4" Round LED Light w/Amber Lens
60042	4" Round Incandescent Light w/Red Lens
60043	4" Round LED Light w/Red Lens
60046	4" Round Incandescent Light w/Amber Lens & Rubber Grommet
60047	4" Round LED Light w/Amber Lens & Grommet
60048	4" Round Incandescent Light w/Red Lens & Rubber Grommet
60049	4" Round LED Light w/Red Lens & Rubber Grommet
68902	Rubber Grommet for 4" Oval LED and Incandescent Lights
60020	5" Rectangular Incandescent Light w/Amber Lens
60021	5" Rectangular LED Light w/Amber Lens
60022	5" Round Incandescent Light w/Red Lens
60023	5" Round LED Light w/Red Lens
60026	5" Rectangular Incandescent Light w/Amber Lens & Grommet
60027	5" Rectangular LED Light w/Amber Lens & Grommet
60028	5" Round Incandescent Light w/Red Lens & Rubber Grommet
60029	5" Round LED Light w/Red Lens & Rubber Grommet
68901	Rubber Grommet for 5" Oval LED and Incandescent Lights



Lights 6.5"

Description

60000	6.5" Oval Incandescent Light w/Amber Lens
60001	6.5" Oval LED Light w/Amber Lens
60002	6.5" Oval Incandescent Light w/Red Lens
60003	6.5" Oval LED Light w/Red Lens
60006	6.5" Oval Incandescent Light w/Amber Lens & Rubber Grommet
60007	6.5" Oval LED Light w/Amber Lens & Grommet
60008	6.5" Round Incandescent Light w/Red Lens & Rubber Grommet
60009	6.5" Round LED Light w/Red Lens & Rubber Grommet
68900	Rubber Grommet for 6.5" Oval LED and Incandescent Lights

LIGHT PARTS



Lighting Accessories

Description

- 23550 ABS Chrome Plastic Light Guard, 137mm x 61mm x 28mm
- 23560 Large Metal Light Guard, 195mm x 65mm x 42mm - Chrome Plated Cast Zinc
- 23570 Stainless Steel Light Guard for Marker Lights, 114mm x 31mm x 30mm
- 68925 4" Round Stainless Steel Locking Bezel w/Hardware
- 68926 2" Round Stainless Steel Locking Bezel w/Hardware
- 68950 6.5" Oval ABS Chrome Bezel w/Hardware
- 68951 5" Rectangular ABS Chrome Bezel w/Hardware
- 68952 4" Round ABS Chrome Bezel w/Hardware
- 68971 5" Round ABS Chrome Bezel w/Visor
- 68972 4" Round ABS Chrome Bezel w/Visor, Hardware Included
- 69900 Wiring Harness w/3 Plugs - Fits 2-Piece Light Bars - Trucklite
- 69905 Wiring Harness w/3 Plugs - Fits 2-Piece Light Bars - Peterson
- 69910 Wire Pig-Tails w/1 Plug - 3-Prong Wire Pig-Tail for 4" Lights - Trucklite Only
- 69912 Wire Pig-Tails w/1 Plug - 3-Prong Wire Pig-Tail for 4" Lights - Peterson Only

RETAIL DISPLAYS



Retail Floor Display Rack

Description

30000 Standard Retail Floor Display Rack System. Manufactured with a Heavy-Gauge Steel Frame with Wood Panels and Aluminum Slats for Long Life. Includes Display Hooks and Hardware. Assembly Required.

Compact Rotating Floor Display

Description

30200 Small Form Factor Rotating Retail Floor Display with Heavy-Gauge Wire Panels and Steel Base and Support. Includes Display Hooks and Hardware. Assembly Required.

A-Frame Retail Floor Display

Description

30005 A-Frame Style Display for Light Bars and Mud Flap Hangers.

Chrome Stack Floor Display

Description

50900 Heavy Duty Stack Display, Free-Standing with Black Enamel Finish

RV AXLE END COVERS



RV Axle End Covers

	O.D.	Height	Material	Center Cap	Packaging
AC319TT-B	3.15"	3.37"	SS	Black	Box of 100
AC319TT-C	3.15"	3.37"	SS	Chrome	Box of 100
AC325TT-B	3.23"	3.31"	SS	Black	Box of 100
AC325TT-C	3.23"	3.31"	SS	Chrome	Box of 100
AC328TT-B	3.26"	3.41"	SS	Black	Box of 100
AC328TT-C	3.26"	3.41"	SS	Chrome	Box of 100
AC425TT-B	4.21"	4.37"	SS	Black	Box of 50
AC425TT-C	4.21"	4.37"	SS	Chrome	Box of 50
AC490TT-B	4.88"	4.72"	SS	Black	Box of 50
AC490TT-C	4.88"	4.72"	SS	Chrome	Box of 50
AC515TT-B	5.12"	4.92"	SS	Black	Box of 50
AC515TT-C	5.12"	4.92"	SS	Chrome	Box of 50

RV = Recreational Vehicle

UNIVERSAL JOINTS



U-Joints

Description

5-153X	1310 Series U-Joint
5-155X	1550 Series U-Joint
5-160X	1410 Series U-Joint
5-170X	1000 Series U-Joint
5-178X	1350 Series U-Joint
5-188X	1480 Series U-Joint
5-279X	1610 Series U-Joint, Full-Round
5-280X	1710 Series U-Joint, Full-Round
5-281X	1810 Series U-Joint, Full-Round
5-407X	1760 Series U-Joint, Full-Round
5-674X	1610 Series U-Joint, Half-Round
5-675X	1710 Series U-Joint, Half-Round
5-676X	1810 Series U-Joint, Half-Round
5-677X	1760 Series U-Joint, Half-Round
5-7000X	7LN Series U-Joint

CAD DRAWINGS

Baby Moon Front Hub Cap



Baby Moon Front Hub Cap

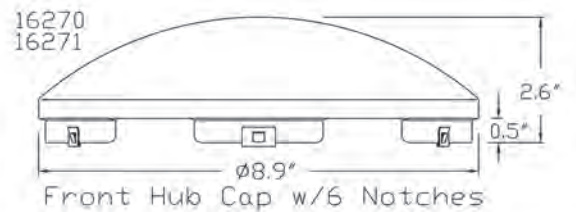
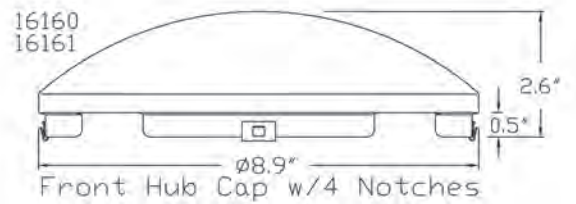

Baby Moon Front Hub Cap (Notches Uneven)



Baby Moon Front Hub Cap



Conical Front Hub Cap



Hubdrometer Front Hub Cap

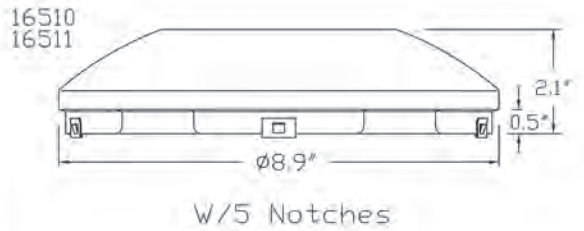
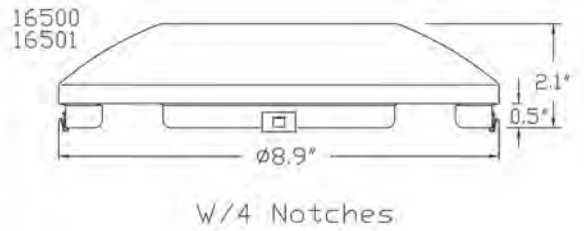

Hubdrometer Front Hub Cap

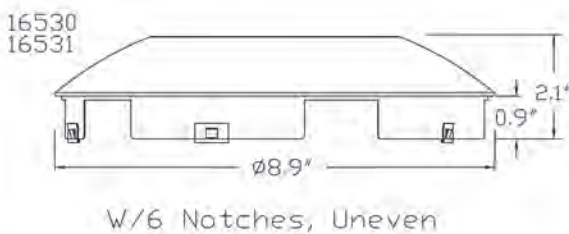
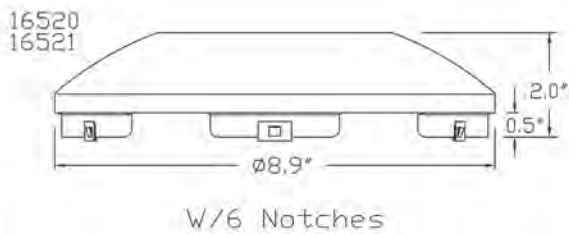

Rear Hub Cap



Rear Hub Cap

16950 16952
16951 16953

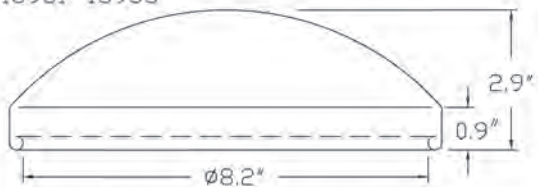

For 3/4" Studs

16970 16972
16971 16973

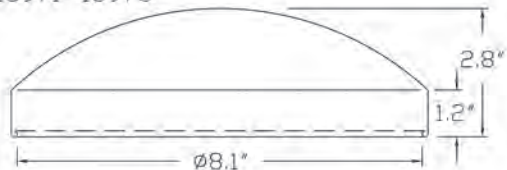

For 3/4" Studs
& 1 1/16" Studs

Rear Hub Cap

16954
16955

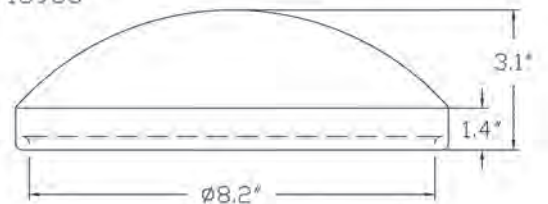

Up to 1" Studs

16980 16982
16981 16983



For Mack Trucks
Over 40,000+ lbs

Rear Hub Cap

16990
16991

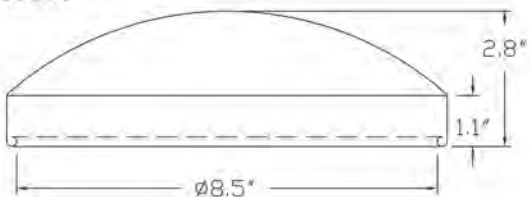

17000 17002
17001 17003

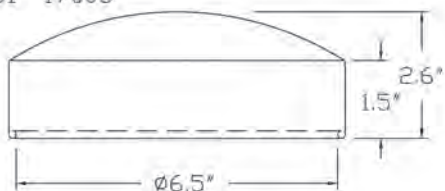

For International Trucks
4000 Series

Rear Hub Cap

16700

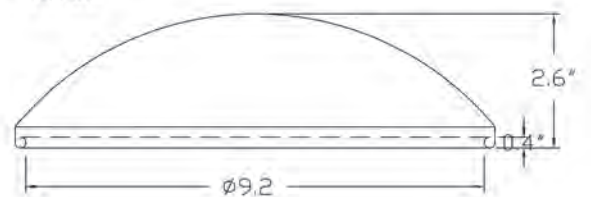

16900
16901
16902
16903

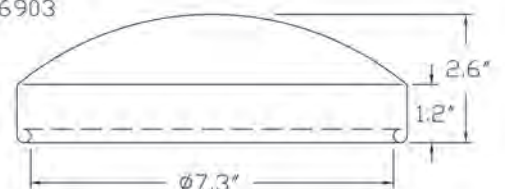

For 1/2" or 9/16 Studs

Conical Rear Hub Cap

16940
16941



For 5/8" Studs

16960

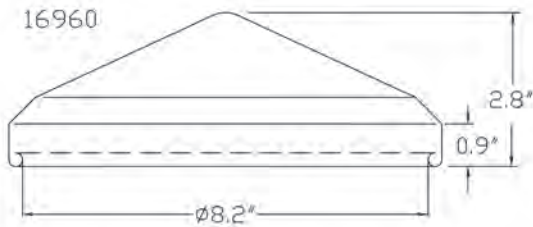

For 3/4" Studs

Hubdrometer Rear Hub Cap

17100
17101
17102
17103

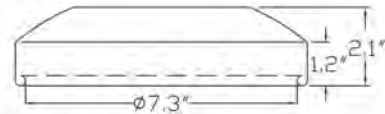

For 1/2" or 9/16" Studs

17120
17121
17122
17123

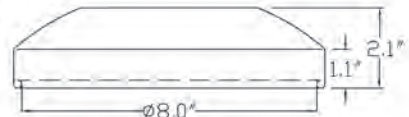

For 5/8" Studs

17130
17131
17132
17133



For 3/4" Studs

Front Axle Cover Kit (Stud-Piloted)

81001
81011

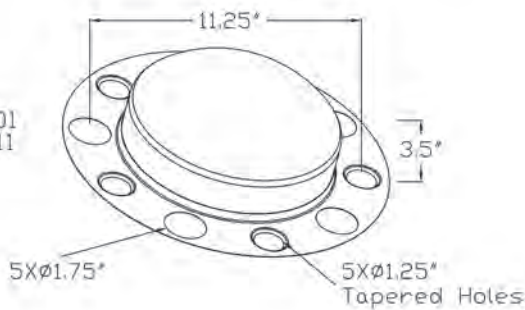

81021
81031

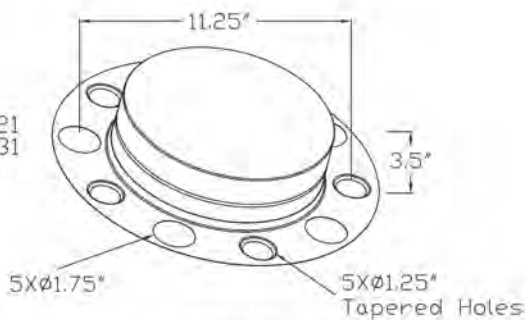

Removable Cap

Front Axle Cover Kit (Hub-Piloted)

81003
81013

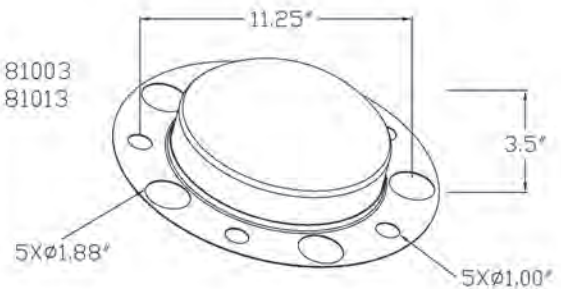

81023
81033

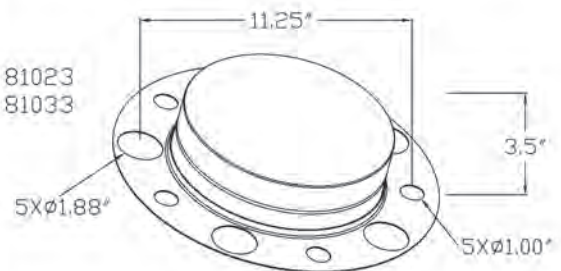

Removable Cap

Front Axle Cover Kit (Hub-Piloted)

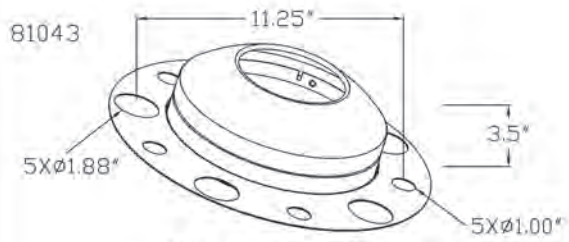

Removable Cap

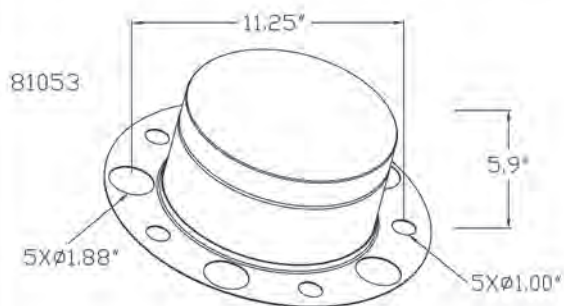

Removable Cap

Rear Axle Cover Kit (Stud-Piloted)

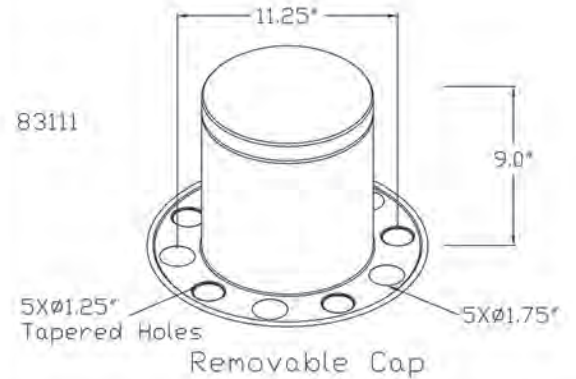
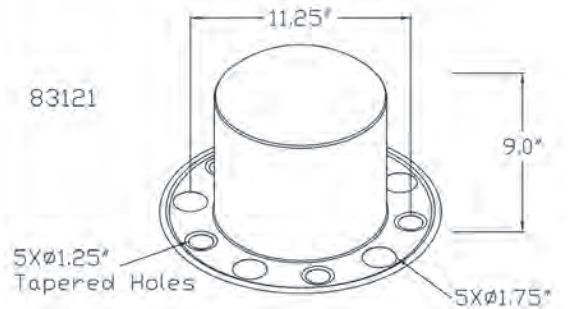

Removable Cap

Rear Axle Cover Kit (Hub-Piloted)

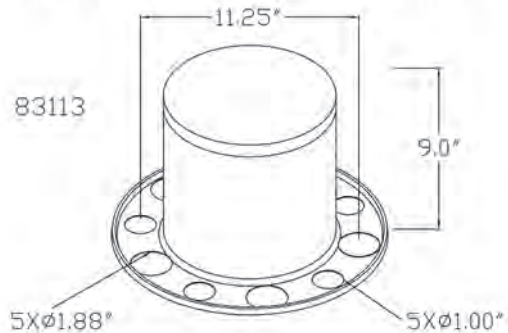
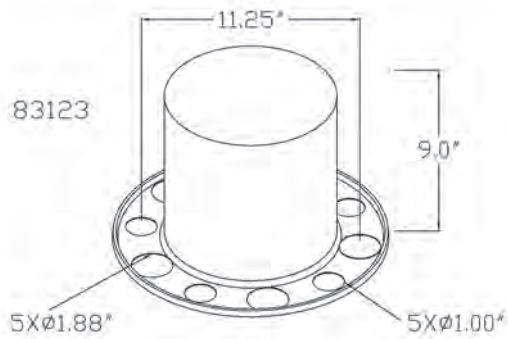

Removable Cap

Rear Axle Cover Kit (Stud-Piloted)

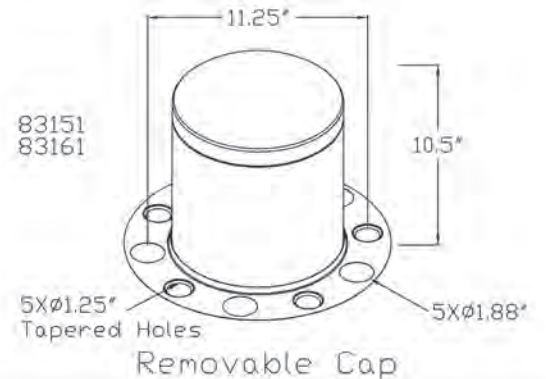
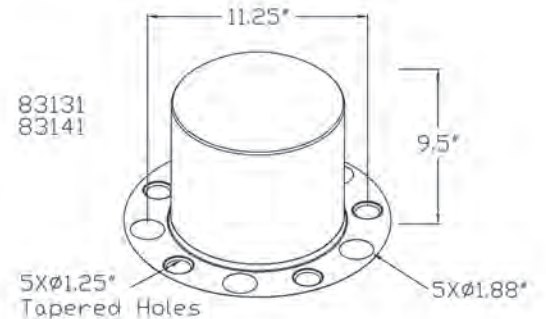

Removable Cap

Rear Axle Cover Kit (Hub-Piloted)

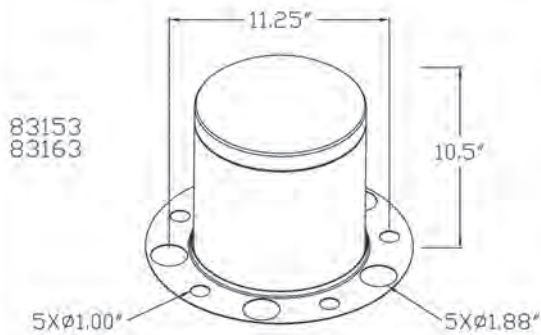
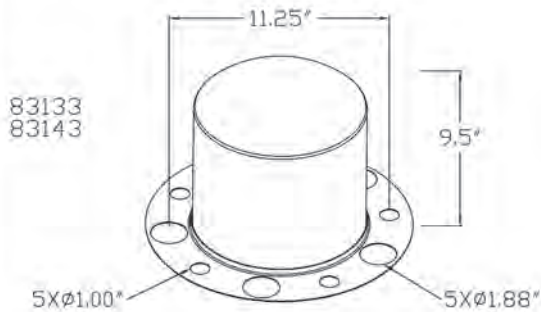

Removable Cap

Rear Axle Cover Kit (Removable Cap)

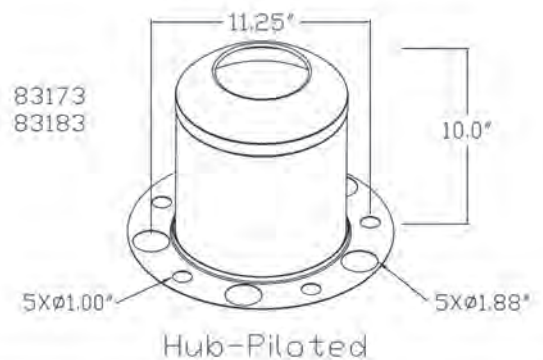
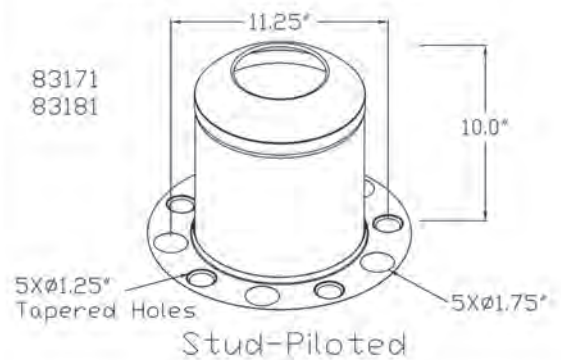

Rear Axle Cover (Hub Cap)

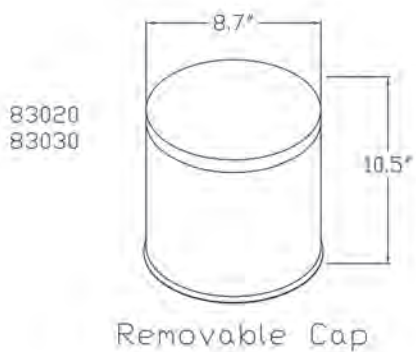
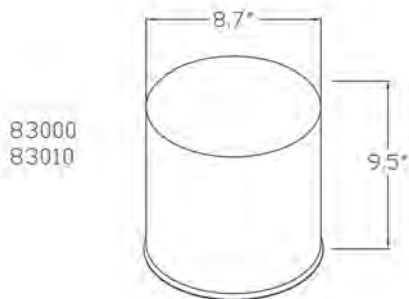

Beauty Ring

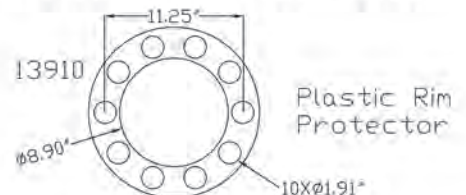
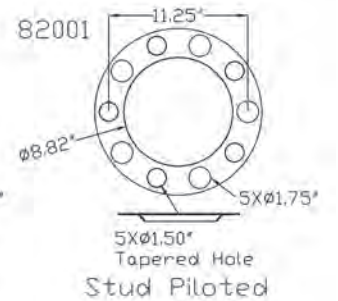
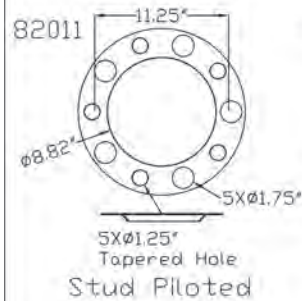
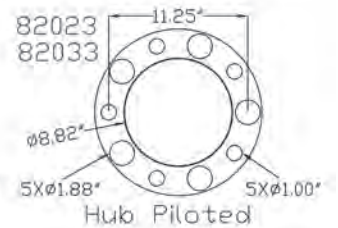
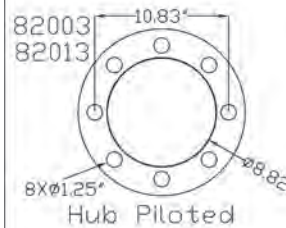

Front Wheel Simulator (Stud-Piloted)

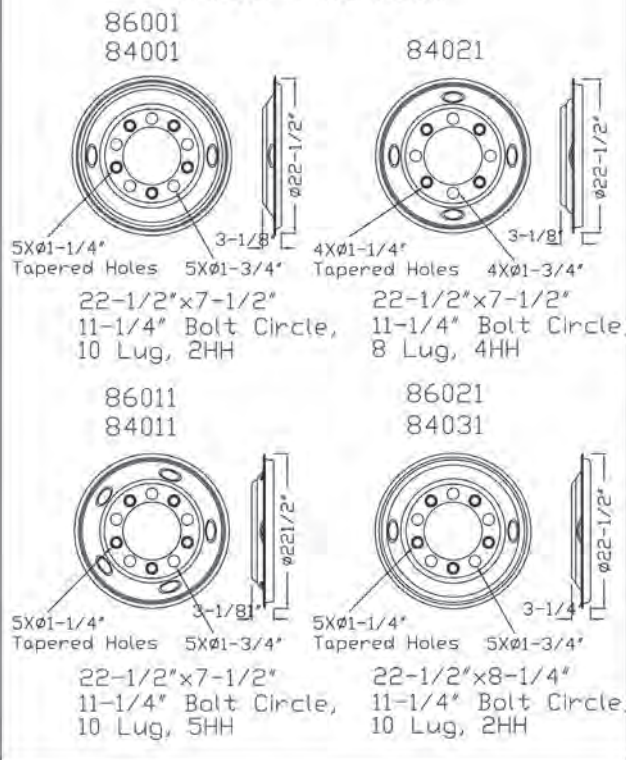

Front Wheel Simulator (Hub-Piloted)

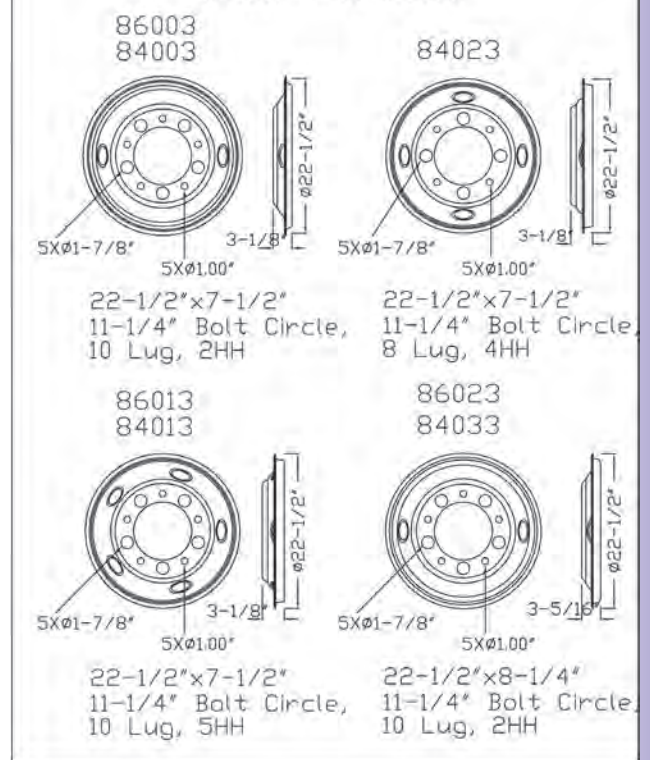

Front Wheel Simulator (Stud-Piloted)

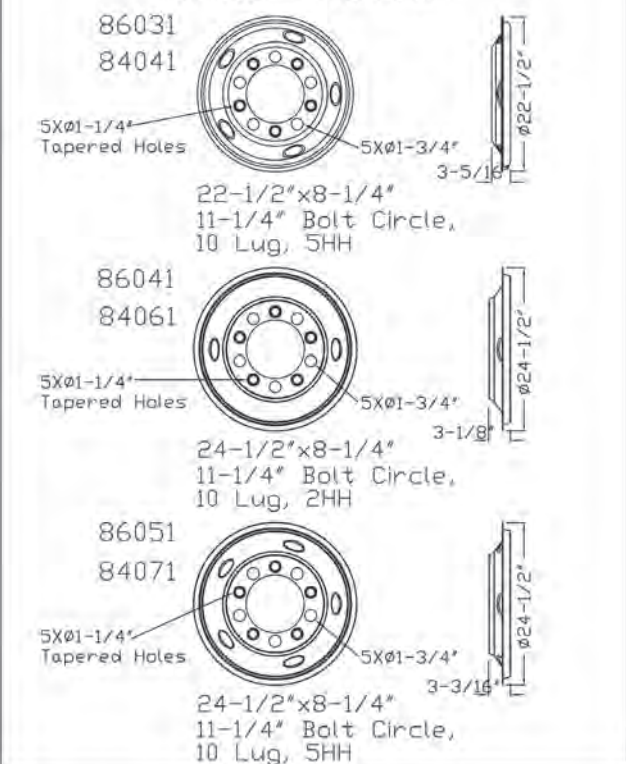

Front Wheel Simulator (Hub-Piloted)

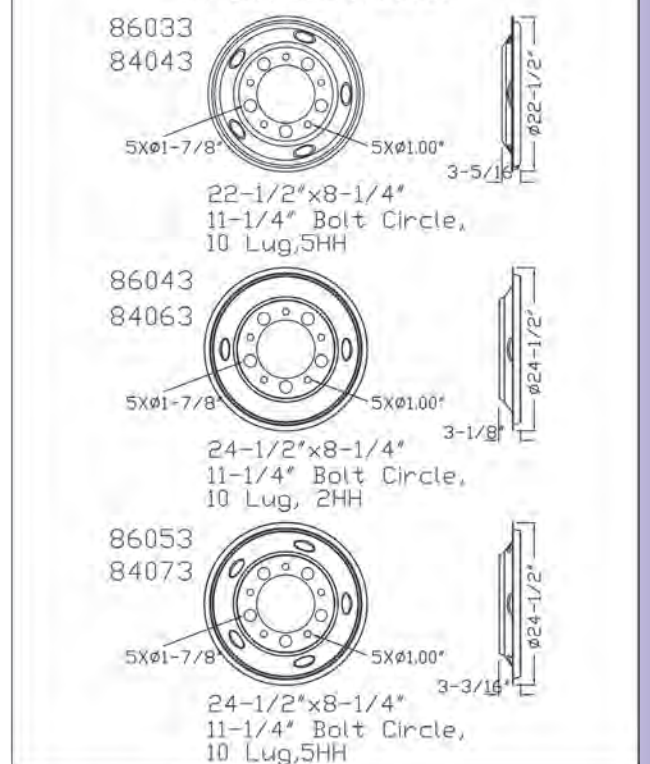

Rear Wheel Simulator (Stud-Piloted)

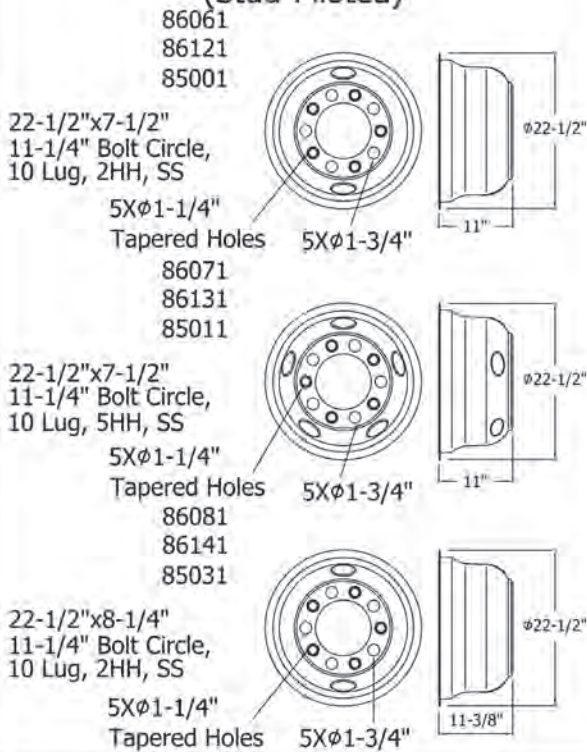

Rear Wheel Simulator (Hud-Piloted)

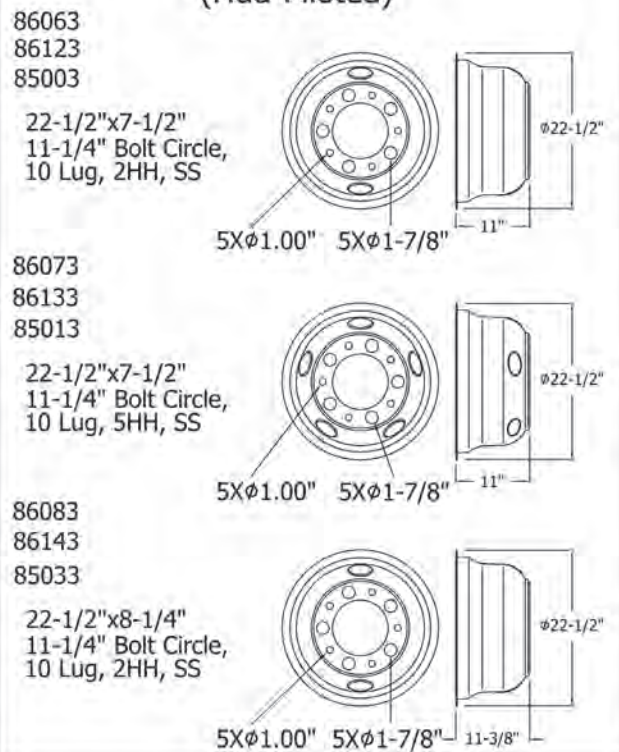

Rear Wheel Simulator (Stud-Piloted)

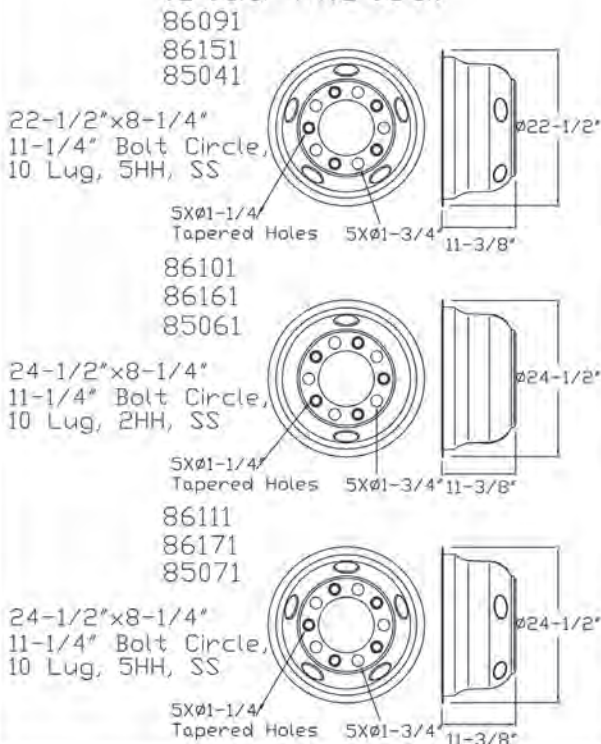

Rear Wheel Simulator (Hud-Piloted)

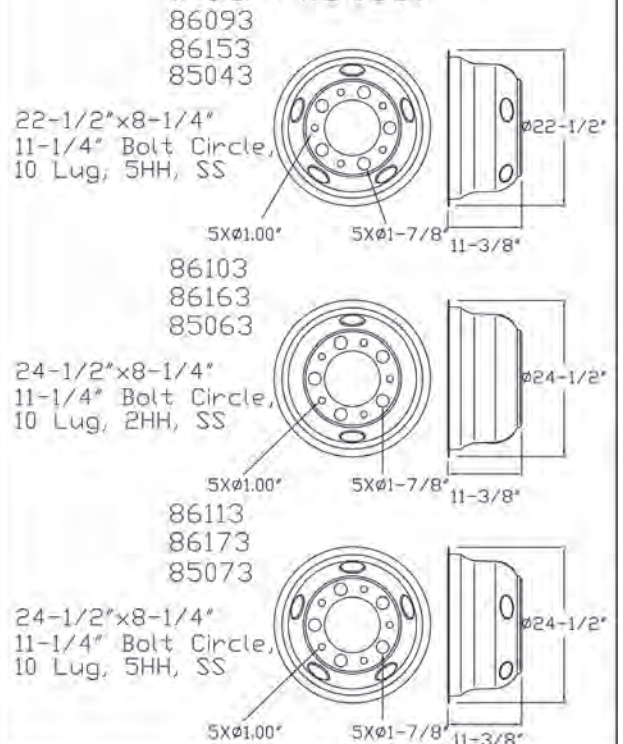

PART NUMBER INDEX

AC319TT-B	113	14317	73	14562	48	15720	9
AC319TT-C	113	14360	73	14580	48	15730	9
AC325TT-B	113	14361	73	14582	48	15740	9
AC325TT-C	113	14362	73	14600	48	15800	10
AC328TT-B	113	14400	46	14601	48	15920	11
AC328TT-C	113	14401	46	14602	48	15921	11
AC425TT-B	113	14402	46	14603	48	15925	11
AC425TT-C	113	14403	46	14610	48	15930	11
AC490TT-B	113	14404	46	14612	48	15960	11
AC490TT-C	113	14405	46	14620	48	15961	11
AC515TT-B	113	14406	46	14622	48	15965	11
AC515TT-C	113	14407	46	15000	7	15971	11
AC-ABS-6	39	14410	46	15010	6	15980	12
5-153X	114	14411	46	15020	6	15981	12
5-155X	114	14412	46	15030	6	15985	12
5-160X	114	14413	46	15040	6	15990	11, 69
5-170X	114	14440	47	15100	6	15991	11, 69
5-178X	114	14450	47	15105	7	16100	30
5-188X	114	14460	47	15110	6	16102	30
5-279X	114	14470	47	15120	6	16110	30
5-280X	114	14480	47	15130	6	16112	30
5-281X	114	14481	47	15140	6	16120	31
5-407X	114	14482	47	15200	6	16121	31
5-674X	114	14483	47	15210	6	16122	31
5-675X	114	14490	47	15220	6	16123	31
5-676X	114	14491	47	15230	6	16150	31
5-677X	114	14492	47	15240	6	16151	31
5-7000X	114	14493	47	15300	7	16152	31
11701	76	14510	47	15500	10	16153	31
11711	76	14511	47	15510	9	16160	29
11721	76	14512	47	15520	9	16161	29
11751	76	14513	47	15530	9	16162	29
11753	76	14530	47	15540	9	16163	29
11755	76	14531	47	15600	9	16164	29
11761	76	14532	47	15605	10	16170	31
11771	76	14533	47	15610	9	16171	31
11775	76	14550	48	15620	9	16172	31
13900	18	14551	48	15630	9	16173	31
13910	18	14552	48	15640	9	16180	29
14006	46	14553	48	15700	9	16181	29
14315	73	14560	48	15710	9	16182	29

16183	29	16910	18	17023	30	17572	64
16240	32	16911	18	17025	30	17573	64
16241	32	16921	18	17026	30	17574	64
16242	32	16930	34	17027	30	17575	64
16243	32	16931	34	17028	30	17580	64
16250	29	16932	34	17100	34	17581	64
16251	29	16933	34	17101	34	17582	64
16252	29	16934	34	17102	34	17583	64
16253	29	16940	35	17103	34	17590	66
16270	29	16941	35	17120	35	17591	66
16271	29	16942	35	17121	35	17592	66
16272	29	16943	35	17122	35	17593	66
16273	29	16950	18, 35	17123	35	17594	66
16500	32	16951	18, 35	17130	18, 36	17595	66
16501	32	16952	35	17131	18, 36	17600	66
16502	32	16953	35	17132	36	17601	66
16503	32	16954	38	17133	36	17602	66
16510	32	16955	38	17500	64, 68	17603	66
16511	32	16956	38	17501	64	17610	65
16512	32	16957	38	17502	64	17612	65
16513	32	16960	36	17503	64	17620	65
16520	33	16961	36	17506	64	17622	65
16521	33	16962	36	17508	64	17630	65
16522	33	16963	36	17510	64	17632	65
16523	33	16970	36	17511	64	17640	65
16530	33	16971	36	17512	64	17642	65
16531	33	16972	36	17513	64	17650	65
16532	33	16973	36	17515	64	17652	65
16533	33	16980	37	17520	64	17660	66
16650	33	16981	37	17522	64	17661	66
16660	33	16982	37	17530	64	17662	66
16670	33	16983	37	17531	64	17663	66
16700	39	16990	36, 37	17532	64	17670	66
16701	39	16991	36, 37	17533	64	17700	66
16702	39	16992	37	17540	65	17701	66
16703	39	16993	37	17541	65	17702	66
16750	39	17000	38	17542	65	17703	66
16760	39	17001	38	17543	65	17710	66
16900	34	17002	38	17550	65	17800	67
16901	34	17003	38	17551	65	17801	67
16902	34	17016	30	17552	65	17802	67
16903	34	17020	30	17553	65	17803	67
16905	36	17021	30	17570	64	17804	67
16906	36	17022	30	17571	64	17805	67

17806	67	18130	60	18604	98	19042	89
17807	67	18132	12, 60	18605	98	19050	89
17808	67	18134	60	18650	97	19051	89
17809	67	18140	60	18651	97	19052	89
17810	67	18142	12, 60	18654	98	19060	89
17811	67	18144	60	18655	98	19061	89
17850	67	18150	60	18700	97	19062	89
17852	67	18152	12, 60	18701	97	19070	89
17860	67	18154	60	18704	98	19071	89
17862	67	18170	12, 62	18705	98	19072	89
17870	67	18200	60	18750	97	19075	89
17872	67	18202	12, 60	18751	97	19081	90
17880	67	18204	60	18754	98	19083	91
17882	67	18210	61	18755	98	19090	90
17980	64	18212	61	18800	97	19101	90
17981	64	18214	61	18801	97	19103	91
18000	59	18220	60	18804	98	19111	90
18002	12, 59	18222	12, 60	18805	98	19113	90
18004	59	18224	60	18850	97	19121	90
18010	59	18230	60	18851	97	19131	91
18011	59	18232	12, 60	18854	98	19132	91
18012	59	18240	60	18855	98	19141	91
18013	59	18242	12, 60	18900	99	19142	91
18014	59	18244	60	18910	99	19151	91
18015	59	18250	61	18940	99	19152	91
18020	59	18252	12, 61	18941	99	19200	91
18022	12, 59	18254	61	18942	99	19210	91
18024	59	18300	61	18945	99	19350	73
18030	59	18302	61	18946	99	19360	73
18032	12, 59	18324	60	18947	99	19401	72
18034	59	18350	61	18960	99	19406	72
18040	59	18352	61	18970	99	19407	72
18042	12, 59	18400	69	18971	99	19412	72
18044	59	18410	69	18972	99	19420	72
18050	59	18500	68	18973	99	19425	72
18052	12, 59	18510	68	18980	99	19901	108
18054	59	18520	68	18990	99	19911	108
18100	60	18530	68	19001	89	19921	108
18102	12, 60	18540	68	19002	89	19931	108
18104	60	18550	68	19020	89	19941	108
18110	12, 62	18560	68	19021	89	19951	108
18120	60	18570	68	19022	89	19961	108
18122	12, 60	18600	97	19040	89	20010	105
18124	60	18601	97	19041	89	20020	105

20030	105	21445	52	21921	44	23450	93
20040	105	21451	53	21921K	44	23451	94
20101	107	21453	53	21925	45	23453	94
20103	107	21455	53	21930	43	23456	93
20111	107	21461	52	21932	43	23460	93
20113	107	21463	52	21954	43	23461	94
20121	107	21471	52	21960	43	23462	94
20123	107	21473	52	21961	43	23463	94
20130	107	21475	52	21962	43	23465	94
20131	107	21481	53	21963	43	23476	93
20132	107	21483	53	21965	43	23480	93
20133	107	21485	53	21967	43	23481	95
20141	107	21600	50	21969	43	23483	95
20143	107	21611	50	21990	43	23484	95
20200	107	21613	50	21991	43	23485	95
20202	107	21621	50	21992	43	23486	95
20210	107	21631	50	22000	43	23488	95
20212	107	21633	50	22001	43	23490	95
21300	106	21641	50	22002	43	23550	111
21301	106	21651	50	22010	43	23560	111
21305	106	21653	50	22012	43	23570	111
21311	106	21661	50	22055	45	23620	101
21315	106	21801	51	22160	49	23630	101
21321	106	21805	51	22170	49	23640	100
21325	106	21811	51	22171	49	23700	104
21330	106	21821	51	22174	49	23701	104
21331	106	21825	51	22403	101	23705	104
21341	106	21831	51	22440	102	23710	104
21351	106	21840	51	22445	102	23711	104
21361	106	21841	51	22450	102	23715	104
21365	106	21843	51	22580	48	23720	104
21371	106	21845	51	23300	96	23721	104
21401	52	21850	51	23310	96	23725	104
21403	52	21851	51	23320	96	23730	100
21411	52	21900	45	23321	96	23800	100
21413	52	21905	45	23340	96	25500	25
21415	52	21906	45	23341	96	25501	25
21421	53	21907	51	23350	96	25502	25
21423	53	21910	44	23360	96	30000	112
21425	53	21910K	44	23361	96	30005	112
21431	52	21911	44	23370	96	30200	112
21433	52	21911K	44	23380	96	40000	8
21441	52	21920	44	23400	96	40010	8
21443	52	21920K	44	23411	96	40020	8

40030	8	60360	25	60621G	23	80093	87
40040	8	60366	25	60622	23	80113	87
40050	8	60372	25	60623	23	80121	86
40060	8	60378	25	60623G	23	80123	87
40070	8	60384	25	60630	23	80131	86
40080	8	60386	25	60631	23	80133	87
40090	8	60500	22	60631G	23	80141	86
50900	112	60501	21	60632	23	80143	87
60000	110	60501G	21	60633	23	81001	13
60001	110	60502	22	60633G	23	81003	13
60002	54, 110	60503	21	64988	109	81011	13
60003	54, 110	60503G	21	64989	109	81013	13
60006	110	60510	22	68900	54, 110	81021	13, 18
60007	110	60511	21	68901	54, 109	81023	13, 18
60008	54, 110	60511G	21	68902	54, 109	81031	13, 18
60009	54, 110	60512	22	68925	111	81033	13, 18
60020	109	60513	21	68926	111	81041	14
60021	109	60513G	21	68950	111	81043	14
60022	54, 109	60520	22	68951	111	81051	14
60023	54, 109	60521	21	68952	111	81053	14
60026	109	60521G	21	68971	111	82001	18
60027	109	60522	22	68972	111	82003	18
60028	54, 109	60523	21	69900	111	82011	18
60029	54, 109	60523G	21	69905	111	82013	18
60040	109	60530	22	69910	111	82023	18
60041	109	60531	21	69912	111	82033	18
60042	54, 109	60531G	21	69950	106	83000	16
60043	54, 109	60532	22	70001	103	83010	16
60046	109	60533	21	70002	103	83020	16
60047	109	60533G	21	70003	103	83030	16
60048	54, 109	60590	22	80021	86	83111	15
60049	54, 109	60591	21	80023	87	83113	15
60300	24	60591G	21	80031	86	83121	15
60301	24	60592	22	80033	87	83123	15
60305	24	60593	21	80041	86	83131	15
60316	24	60593G	21	80043	87	83133	15
60320	24	60610	23	80051	86	83141	15
60321	24	60611	23	80053	87	83143	15
60325	24	60611G	23	80061	86	83151	15
60326	24	60612	23	80063	87	83153	15
60330	24	60613	23	80071	86	83161	15
60331	24	60613G	23	80073	87	83163	15
60335	24	60620	23	80081	86	83171	16
60336	24	60621	23	80083	87	83173	16

83181	16	86091	78
83183	16	86093	78
84001	80	86101	78
84003	80	86103	78
84011	80	86111	78
84013	80	86113	78
84031	80	86121	79
84033	80	86123	79
84041	80	86131	79
84043	80	86133	79
84061	80	86141	79
84063	80	86143	79
84071	80	86151	79
84073	80	86153	79
85001	81	86161	79
85003	81	86163	79
85011	81	86171	79
85013	81	86173	79
85031	81	87001	84
85033	81	87003	85
85041	81	87011	84
85043	81	87013	85
85061	81	87021	84
85063	81	87023	85
85071	81	87031	84
85073	81	87033	85
860 01	77	87041	84
86003	77	87043	85
86011	77	87051	84
86013	77	87053	85
86021	77	87061	84
86023	77	87063	85
86031	77	87071	84
86033	77	87073	85
86041	77	87081	84
86043	77	87083	85
86051	77	87091	84
86053	77	87093	85
86061	78		
86063	78		
86071	78		
86073	78		
86081	78		
86083	78		

KEYBOARD INDEX

A

ABS Axle Cover Center Caps	11
ABS Axle Covers	6, 7, 8, 9, 10
ABS Bezels	111
ABS Black Chrome Front Axle Covers	7
ABS Black Chrome Nut Covers	62
ABS Black Chrome Rear Axle Covers	10
ABS Chrome Nut Covers	59, 60, 61, 62
ABS Front Axle Covers	6, 7, 8
ABS Front Hub Cover Kits	6, 7, 8
ABS Hubdometer Caps - Front	11
ABS Hubdometer Caps - Rear	11
ABS Light Guards	111
ABS Nut Cover Removal Tools	69
ABS Rear Axle Covers	9, 10
ABS Rear Hub Cover Kits	9, 10
ABS Removable Center Caps- Front	11
ABS Removable Center Caps- Rear	11
ABS Replacement Nut Covers	12
ABS Trailer Hub Caps	39
Acorn Nut - Decorative	101
Adapter	7, 10, 11, 69
Adjustable Nut Cover Removal Tool	69
A-Frame Retail Floor Display	112
Air Horn	94
Air Horn Replacement Kits	95
Aluminum Wheels - Front Hub Caps	30
Anti-Sail Bracket	49
Axle Cover Replacement Parts	18
Axle End Covers	113

B

Baby Moon Hub Caps - Front	29, 30
Baby Moon Hub Caps - Rear	34, 35, 36, 37, 38
Beauty Rings	18
Bezels	111
Bolt Covers	68
Boot Brush	100
Bottle Jacks	104
Bottom Weights	47, 48
Bracket and Mount for Mirrors	91
Bullet Nut - Decorative	101
Bumper Guide Replacement Parts	99
Bumper Guides	39, 97, 98

C

Chain-Style License Frames	105
Chrome Bolt Covers	68
Chrome License Plate Holders	107
Chrome Light Bars	51
Chrome Nut Covers	64, 65, 66, 67
Chrome Stack Floor Display	112
Chrome Stacks	21, 22, 23
Chrome Stacks - Bull Horn	21
Chrome Stacks Display	21
Chrome Stacks - Miter Cut	22
Chrome Stacks - Turn Out	21
Clamp - Bumper Guide	99
Clamp - Quarter Fender	73
Clips	33, 39
Collar - Bumper Guide	99
Compact Rotating Floor Display	112
Cone Style Hub Caps - Front	31, 32
Cone Style Hub Caps - Rear	35, 36
Conspicuity Products	45
Conspicuity Reflectors	45
Convex Mirrors	89, 91

D

Dash Fans	102
Decorative Hardware	101
Display Racks	112

E

Economy-Style Mud Flap Hangers	44
Electric Dash Fans	102

F

Fans	102
Five-Spoke Front Axle Cover	7
Five-Spoke Rear Axle Cover	10
Flat Clamp for Bumper Guide	99
Frames - License	105
Front Axle Cover Kit	6, 7, 8, 11, 13, 14
Front Axle Covers	6, 7, 8, 11, 13, 14, 18
Front Hub Cap Clips	33
Front Hub Caps	29, 30, 31, 32, 33
Front Wheel Cover Kits	84, 85
Front Wheel Covers	84, 85, 86, 87
Front Wheel Simulator Kits	77
Front Wheel Simulators	77, 80

G	
G-Clamp for Bumper Guide	99
H	
Haz-Mat Placards	100, 101
Haz-Mat Signs	100, 101
Heated Mirrors	90, 91
Heat Shield Mounts	25
Heat Shields	24
High Hats - ABS	9, 10
High Hats - Chrome	15, 16
High Hats - Stainless Steel	15, 16
Hinged Permit Holders	108
Horn Covers	96
Hub Cap Clips	33, 39
Hub Caps - Front	29, 30, 31, 32, 33
Hub Caps - Rear	34, 35, 36, 37, 38
Hub Cover Kits - Front	13, 14
Hub Cover Kits - Rear	15, 16
Hubdrometer - Front Hub Caps	32, 33
Hubdrometer - Rear Hub Caps	34, 35, 36
Hydraulic Bottle Jacks	103, 104
I	
Installation Tools - Adapter	11, 69
Installation Tools - Nut Cover	11, 69
International Rear Hub Caps	38
J	
Jacks	104
L	
LED Lights	109, 110
Lens - Bumper Guide	99
License Frames	105
License Panels - Rear	106
License Plate Frames	105
License Plate Holders	107
License Plate Lights	106
Light Bars - 1 Piece	50
Light Bars - 2 Piece	51
Light Brackets	52
Light-Duty Wheel Simulator Sets	76
Light Guards	111
Lighting Accessories	111
Lights	54, 109
Lights - Bezels	111
Lights - License Plate	106

Lights - Rubber Grommet	109, 110
Low-Boy Jacks	104
M	
Mack Rear Hub Caps	37
Merchandising Displays	112
Merritor Axle Front Hub Caps	31
Metal Retaining Washer	12
Mirrors	89, 90, 91
Mount - Convex Mirror	91
Mounting Bracket - Mud Flap Holder	45
Mounting Bracket - Trailer Wheel Hub Caps	39
Mud Flap Bottom Weights	47
Mud Flap Bottom Weight with Cut-out	48
Mud Flap Hanger Replacement Parts	45
Mud Flap Hangers	43, 44
Mud Flap Holders	44
Mud Flap - Quarter Fender	73
Mud Flap Top Weights	46
Muffler Clamps	25
N	
Navistar Rear Hub Caps	38
Nut Cover Installation Tools	69
Nut Cover Removal Tools	69
Nut Covers	59, 60, 61, 62, 64, 65, 66, 67
Nut Covers - ABS	59, 60, 61, 62
Nut Covers - Chrome	64, 65, 66, 67
Nut Covers - Reflector	65, 67
Nut Covers - Stainless Steel	64, 65, 66, 67
Nut Cover with Reflectors	65, 67
O	
One-Piece Deluxe Light Bars	50
P	
Permit Holders	108
Permit Mounts	108
Pig Tail - Wiring Harness	111
Placards	101
Plastic Rim Protector	12
Push-On Nut Covers	59, 60, 61
Q	
Quarter Fender Mounting Brackets	73
Quarter Fenders	72, 73
Quarter Fender Top Mud Flap	73

R

Racks	112
Rear Axle Cover Kit	9, 10, 15, 16
Rear Axle Covers	9, 10, 15, 16, 18
Rear Hub Cap for International	38
Rear Hub Caps	34, 35, 36, 37, 38
Rear Hub Cover Kits	9, 10, 15, 16
Rear License Panels	106
Rear Wheel Simulator Kit	78, 79
Rear Wheel Simulators	78, 79, 81
Reflector Nut Covers	59, 60, 61, 65, 66, 67
Repair Kit - Bumper Guide	99
Repair Kits - Air Horn	95
Replacement Lens - Bumper Guide	99
Replacement Lights	54
Replacement Part for Spring-Loaded Light Bars	51
Replacement Spring - Light Bars	51
Replacement Spring - Mud Flap Hangers	45
Retail Floor Display Rack	112
Retaining Washer, Metal	12
Rim Protector	12, 18
Rotating Floor Display	112
Rubber Grommets	109, 110
RV Axle End Covers	113

S

Signs	101
Simulator Kits - Front Wheel	77
Simulator Kits - Rear Wheel	78, 79
Simulator Sets - Light Duty	76
Simulators - Front Wheel	80
Simulators - Rear Wheel	81
Spoke ABS Chrome Nut Cover	62
Spring-Loaded Light Bars	51
Spring-Loaded Mud Flap Hanger	43
Stainless Steel Bezels	111
Stainless Steel License Plate Holders	107
Stainless Steel Light Bars	50, 51
Stainless Steel Light Guards	111
Stainless Steel Nut Covers	64, 65, 66, 67
Stainless Steel Quarter Fenders	72
Steel Washer - Hub Cover	12

T

Threaded Nut Covers	60, 62
Top Mud Flap for Quarter Fender	73
Top Weights	46
Trailer Hub Cap Accessories	39
Trailer Hub Caps	39
Train Horns	93
Tripod Mount - Convex Mirror	91
Tube Mount - Quarter Fender	73
Twist-on Nut Covers - ABS	60, 62
Two-Piece Deluxe Light Bar	51

U

U-Joints	114
----------	-----

W

West Coast Mirrors	90, 91
Wheel Cover Kits - Front	84, 85
Wheel Covers - Front	86, 87
Wiring Harness	111

GENERAL POLICIES

SALES POLICY

American Chrome® sells for distribution only. We do not make our products directly available to consumers.

ORDERS

Minimum \$75 USD. A processing fee of \$10 USD will be added to all orders less than the minimum to offset the cost of handling / processing small orders. Orders must be placed in standard box quantities³. A 5% 'break' charge will be added to each item ordered in less than box quantities.

CREDIT

Any customer wishing to have a credit account with American Chrome® should contact our customer service department for a credit application. Upon approval, American Chrome® will establish a credit account in the customer's name. All orders will be shipped COD for customers placing orders without an approved credit application and credit account.

TERMS

Terms are provided only to customers who have an approved credit account with American Chrome®. Payment terms are net 30 days. A service charge of 1.5% per month will be assessed on all invoices past due.

WARRANTY

American Chrome® warrants our products to the original purchaser¹ to be free from defects in material or workmanship for one year from the date of purchase². This warranty does not apply to any alterations, abuse, misuse, accident, or damage due to corrosive environments, including exposure to acid washes, which can affect the plating and surface finish of chrome and stainless steel products.

PRICES

American Chrome® reserves the right to change or modify pricing without prior notice.

¹Original purchaser is the distributor to whom American Chrome® initially sold the product.

²Date of purchase is the documented date the order was placed.

³Standard box quantities are available by contacting our customer service department.

SHIPPING & FREIGHT POLICIES

GENERAL TERMS AND CONDITIONS

American Chrome® has negotiated favorable shipping rates with several major carriers for the lowest possible shipping cost for our customers and reserves the right to choose the most economical carrier for any order. In the event a customer requests a specific carrier or special routing, charges in addition to those listed below may apply.

U.S. FREIGHT-PREPAID POLICY

Except for those customers participating in particular buying groups, or who have negotiated special rates for shipping, customers can qualify for freight prepaid under the following options:

\$1000 total order value or higher, excluding the following oversize/overweight product(s): Quarter Fenders, Mud Flap Holders, Chrome Stacks, Heat Shields, Hydraulic Jacks, and Train Horns.

\$2000 total order value or higher, which may include oversize/overweight product(s).

CANADIAN FREIGHT-PREPAID POLICY

Orders subject to special arrangements.

PRIORITY SHIPPING

Specific carrier requests, special routing, and/or special shipping terms for UPS and FedEx are additional at the customer's expense.

WARRANTY & RETURN POLICIES

WARRANTY

American Chrome® warrants our products to the original purchaser¹ to be free from defects in material or workmanship for one year from the date of purchase².

In the unlikely event of a warranty claim, customers must contact customer service to obtain a return authorization number. American Chrome® will not honor any warranty claims without proof of purchase and receipt of defective product.

Due to the nature of our products, exposure to the elements and particular harsh chemicals can damage the finish. Care must be taken to ensure these products maintain their shine and finish. American Chrome® will not be responsible for products damaged by alterations, misuse, abuse, accidents, or damage due to exposure to harsh chemicals and cleaning agents which can damage the chrome or discolor stainless steel.

RETURNS

The following conditions apply to all returns:

Customers must obtain a return authorization number from our customer service department prior to sending any merchandise back for any reason. All unauthorized returns will be refused.

Annual return allowance will not exceed 5% of prior calendar years' purchases.

Merchandise returned in original, unopened cartons are subject to a minimum handling and restocking charge of 15%. Merchandise returned in non-original packaging are subject to a re-packaging charge of 25%. Returned items may be replaced by product of equal or greater value, freight collect. Discontinued items are not eligible for return or credit.

¹Original purchaser is the distributor to whom American Chrome® initially sold the product.

²Date of purchase is the documented date the order was placed.

CERTIFICATIONS

American Chrome® is proud to be:

- ISO 9001:2008 Certified
- ISO 14001:2004 Certified
- Certified Minority Business (CMBDC)
- Certified Women's Business Enterprise (WBENC)



ABOUT AMERICAN CHROME®



American Chrome Company's warehouse and distribution center is located in Bolingbrook, IL. With 80,000 square feet of office and warehouse, state-of-the-art inventory control systems and full EDI transaction capability, ACC is well-equipped to provide a full range of Chrome, Stainless Steel, and ABS plastic accessories for heavy, medium and light-duty vehicles.



Millimeters to Inches conversion table

Millimeters	Inches	Millimeters	Inches	Millimeters	Inches	Millimeters	Inches
		20	0.78	50	1.96	80	3.14
0.1	0.003	21	0.82	51	2.00	81	3.18
0.2	0.007	22	0.86	52	2.04	82	3.22
0.3	0.011	23	0.90	53	2.08	83	3.26
0.4	0.015	24	0.94	54	2.12	84	3.30
0.5	0.019	25	0.98	55	2.16	85	3.34
0.6	0.023	26	1.02	56	2.20	86	3.38
0.7	0.027	27	1.06	57	2.24	87	3.42
0.8	0.031	28	1.10	58	2.28	88	3.46
0.9	0.035	29	1.14	59	2.32	89	3.50
1	0.03	30	1.18	60	2.36	90	3.54
2	0.07	31	1.22	61	2.40	91	3.58
3	0.11	32	1.25	62	2.44	92	3.62
4	0.15	33	1.29	63	2.48	93	3.66
5	0.19	34	1.33	64	2.51	94	3.70
6	0.23	35	1.37	65	2.55	95	3.74
7	0.27	36	1.41	66	2.59	96	3.77
8	0.31	37	1.45	67	2.63	97	3.81
9	0.35	38	1.49	68	2.67	98	3.85
10	0.39	39	1.53	69	2.71	99	3.89
11	0.43	40	1.57	70	2.75	100	3.9
12	0.47	41	1.61	71	2.79	200	7.8
13	0.51	42	1.65	72	2.83	300	11.8
14	0.55	43	1.69	73	2.87	400	15.7
15	0.59	44	1.73	74	2.91	500	19.6
16	0.62	45	1.77	75	2.95	600	23.6
17	0.66	46	1.81	76	2.99	700	27.5
8	0.70	47	1.85	77	3.03	800	31.4
19	0.74	48	1.88	78	3.07	900	35.4
		49	1.92	79	3.11	1000	39.3

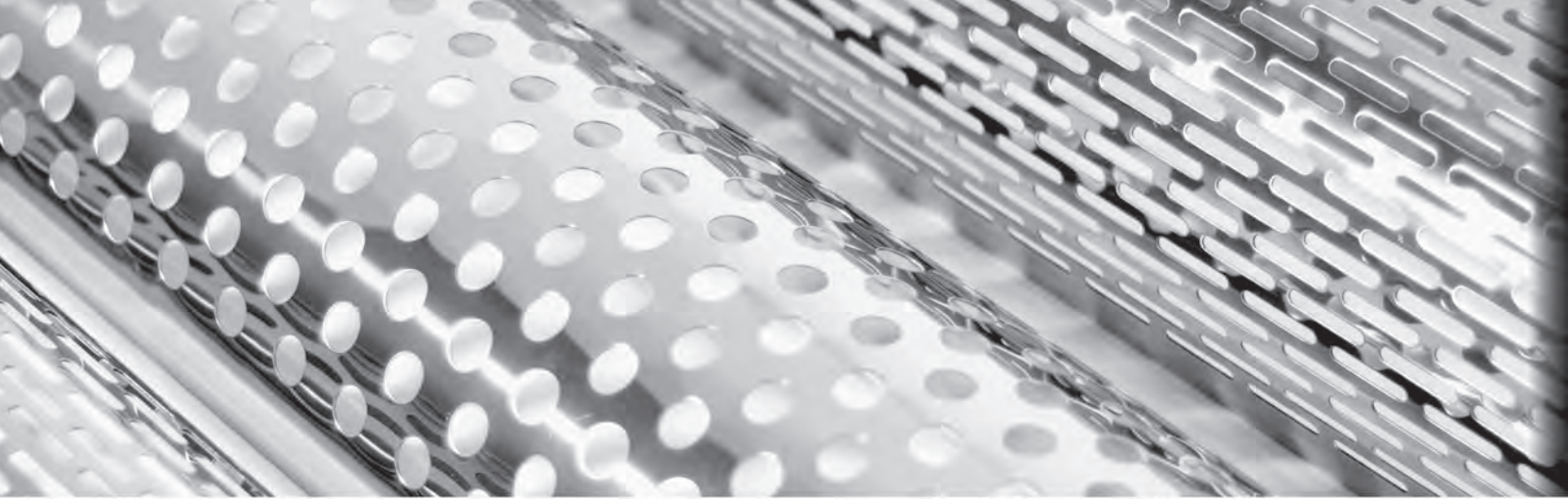

ACC[®]
AMERICAN CHROME